

# Dialog 4224 Operator / Dialog 3214

BusinessPhone Communication Platform

## User Guide



**Aastra**

EN/LZTBS 170 340 R2A

© Aastra Telecom Sweden AB 2008. All rights reserved.

## Table of Contents

	page
Welcome .....	4
Description .....	6
Attendance .....	19
Incoming Calls .....	21
Outgoing Calls .....	23
Phone Book .....	34
During Calls .....	35
Call Ordering .....	42
Call Metering .....	45
Call Forwarding .....	54
Absence Information .....	57
Messages .....	62
Security .....	73
Group Features .....	76
ISDN Facilities .....	81
Other Useful Features .....	86
Write Text .....	92
Accessories .....	94
Useful Hints .....	100
Installation .....	101
Glossary .....	112
Index .....	116

## Welcome

Welcome to the User Guide for the Dialog 4224 Operator / Dialog 3214 in the BusinessPhone Communication Platform from Aastra. The BusinessPhone Communication Platform consists of BusinessPhone Compact, BusinessPhone 50, BusinessPhone 128i and BusinessPhone 250.

The features described in this User Guide are related to version 7.0 or higher of the BusinessPhone Communication Platform. Some might not work in earlier versions of the system and/or might be protected by a license that has to be bought separately.

The User Guide describes the facilities of the BusinessPhone Communication Platform and the Dialog 4224 Operator / Dialog 3214 with a default programming. There may be some differences in the way your phone is programmed. Please consult your system administrator if you need further information.

This guide will demonstrate how the Operator's Console helps operators handle the functions of the BusinessPhone Communication Platform. The Dual-Function keys allow two functions to be combined on the same keys.

The latest version of this User Guide can also be downloaded from: <http://www.aastra.com>

**Note:** *Dialog 4224 Operator / Dialog 3214 is a system telephone, i.e. it can only be used for an Aastra private branch exchange that supports this type of telephone.*

## Copyright

All rights reserved. No parts of this publication may be reproduced, stored in retrieval systems, or transmitted in any form or by any means, electronic, mechanical, photocopying, recording or otherwise, without prior written permission of the publisher except in accordance with the following terms.

If this publication is made available on Aastra media, Aastra gives its consent to downloading and printing copies of the content provided in this file only for private use and not for redistribution. No parts of this publication may be subject to alteration, modification or commercial use. Aastra will not be liable for any damages arising from use of an illegal modified or altered publication.

Aastra is a registered trademark of Aastra Technologies Limited. All other trademarks mentioned herein are the property of their respective owners.

---

## Warranty

AASTRA MAKES NO WARRANTY OF ANY KIND WITH REGARD TO THIS MATERIAL, INCLUDING, BUT NOT LIMITED TO, THE IMPLIED WARRANTIES OF MERCHANTABILITY AND FITNESS FOR A PARTICULAR PURPOSE. Aastra shall not be liable for errors contained herein nor for incidental or consequential damages in connection with the furnishing, performance or use of this material.

---

## Declaration of Conformity

*Hereby, Aastra Telecom Sweden AB, SE-126 37 Hågersten, declares that this telephone is in conformity with the essential requirements and other relevant provisions of the R&TTE directive 1999/5/EC.*

Details to be found at: <http://www.aastra.com/sdoc>



Description

## Description

### Dialog 4224 Operator

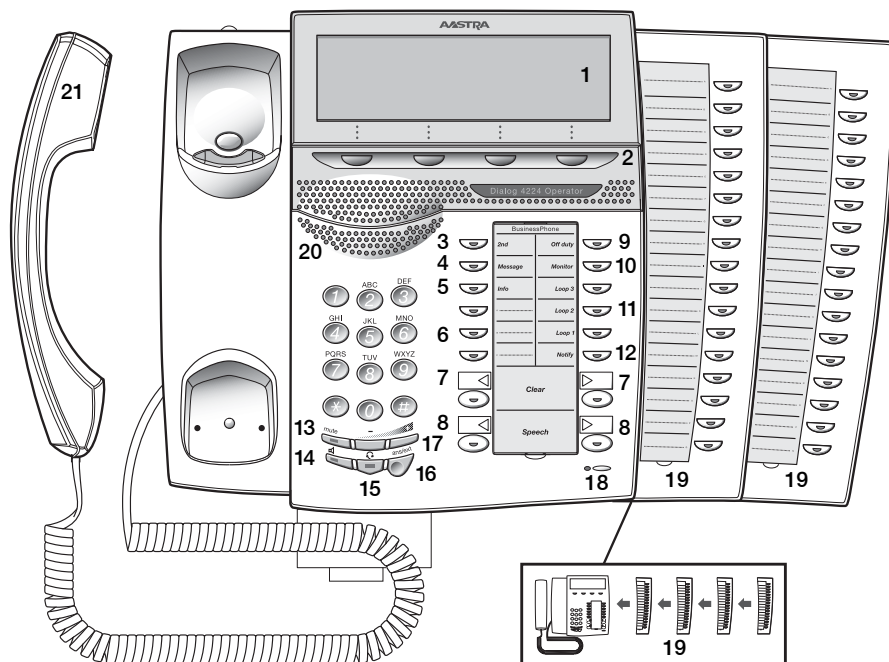

- 1 Display**  
5x40 characters. See section [“Display info”](#) on page 14.
- 2 Menu Function keys**  
The functions depend on the traffic state and will be shown on the last line of the display. When you are requested to **(see display)**, press the required key to access the function.
- 3 2nd**  
Key for access to secondary key functions (These functions are stated on the second line of the corresponding key).
- 4 Message**  
To send and receive messages. See section [“Messages”](#) on page 62.
- 5 Info**  
To enter information. See section [“Absence Information”](#) on page 57.
- 6 Dual-Function programmable keys**  
Storing numbers, program functions.
- 7 Clear key left / Clear key right**  
To disconnect the left or right call, see section [“Incoming Calls”](#) on page 21.
- 8 Speech left / Speech right**  
To have speech connection with the left or right displayed caller. Also used to intrude on a busy extension. See sections [“Incoming Calls”](#) on page 21 and [“Outgoing Calls”](#) on page 23.
- 9 Off Duty**  
Sets the console in Off Duty state. See section [“Attendance”](#) on page 19.
- 10 Monitor**  
To monitor a call on hold. See sections [“Supervise long distance calls”](#) on page 32 and [“Individual Hold and monitor”](#) on page 39.
- 11 Loop 1 / 2 / 3**  
To put calls on hold or camp-on calls. See sections [“Outgoing Calls”](#) on page 23 and [“During Calls”](#) on page 35.
- 12 Notify**  
To reserve an extension or external line when you receive busy extension or external line. See section [“Outgoing Calls”](#) on page 23.

Description

- 13 Mute**  
To switch the microphone on or off. See section [“During Calls”](#) on page 35.
- 14 Loudspeaker on/off**  
To switch the loudspeaker on or off. See section [“During Calls”](#) on page 35.
- 15 Headset key**  
See section [“Headset - Dialog 4224 Operator”](#) on page 96.
- 16 Answer/Extend / Enter**  
a. To answer/extend calls. See sections [“Incoming Calls”](#) on page 21, [“Outgoing Calls”](#) on page 23, [“Call Metering”](#) on page 45, [“Group Features”](#) on page 76 and [“Other Useful Features”](#) on page 86.  
b. To enter/select information. See sections [“Attendance”](#) on page 19 and [“Messages”](#) on page 62.
- 17 Volume control**
- 18 Microphone**
- 19 Optional key panel**  
17 Dual-Function programmable keys per key panel.  
Four panels can be connected.
- Note: Use only optional key panels of type DBY 419 01.*
- 20 Loudspeaker**
- 21 Handset with hearing aid function**
- Please note: The handset may attract and retain small metal objects in the earcap region.*



## Dialog 3214

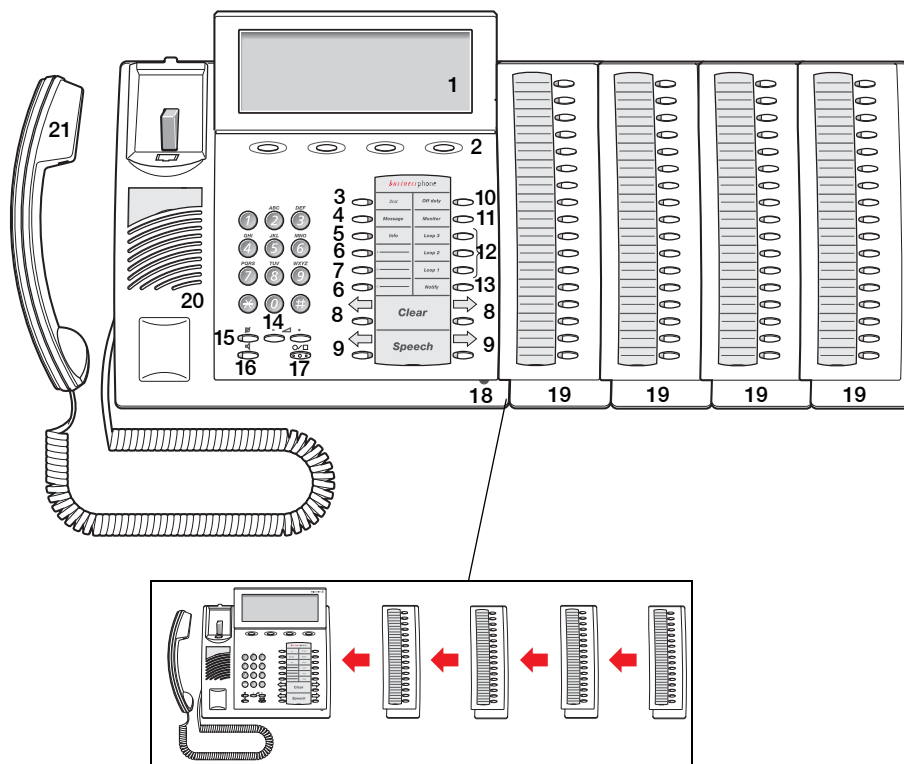

- 1 **Display**  
5x40 characters. See section “[Display info](#)” on page 14.
- 2 **Menu Function keys**  
The functions depend on the traffic state and will be shown on the last line of the display. When you are requested to **(see display)**, press the required key to access the function.
- 3 **2nd**  
Key for access to secondary key functions (These functions are stated on the second line of the corresponding key).
- 4 **Message**  
To send and receive messages. See section “[Messages](#)” on page 62.

- 5 Info**  
Enter information. See section "[Absence Information](#)" on page 57.
- 6 Dual-Function programmable keys (A-C)**  
Storing numbers, program functions.
- 7 Dual-Function programmable key (B) / Headset key**
  - a. Storing numbers and program functions.
  - b. The Headset function is only available with option unit (DBY 410 02) installed. The Headset key is programmed by the system administrator. See section "[Accessories](#)" on page 94.
- 8 Clear key left / Clear key right**  
To disconnect the left or right call, see section "[Incoming Calls](#)" on page 21.
- 9 Speech left / Speech right**  
To have speech connection with the left or right displayed caller. Also used to intrude on a busy extension. See sections "[Incoming Calls](#)" on page 21 and "[Outgoing Calls](#)" on page 23.
- 10 Off Duty**  
Sets the console in Off Duty state. See section "[Attendance](#)" on page 19.
- 11 Monitor**  
To monitor a call on hold. See sections "[Supervise long distance calls](#)" on page 32 and "[Individual Hold and monitor](#)" on page 39.
- 12 Loop 1 / 2 / 3**  
To put calls on hold or camp-on calls. See sections "[Outgoing Calls](#)" on page 23 and "[During Calls](#)" on page 35.
- 13 Notify**  
To reserve an extension or external line when you receive busy extension or external line. See section "[Outgoing Calls](#)" on page 23.
- 14 Volume control**
- 15 Mute**  
To switch the microphone on or off. See section "[During Calls](#)" on page 35.
- 16 Loudspeaker on/off**  
To switch the loudspeaker on or off. See section "[During Calls](#)" on page 35.

**17 Answer/Extend / Enter**

- a. To answer/extend calls. See sections “[Incoming Calls](#)” on page 21, “[Outgoing Calls](#)” on page 23, “[Call Metering](#)” on page 45, “[Group Features](#)” on page 76 and “[Other Useful Features](#)” on page 86.
- b. Enter/select information. See sections “[Attendance](#)” on page 19 and “[Messages](#)” on page 62.

**18 Microphone**

**19 Optional key panel (A-Q)**

17 Dual-Function programmable keys per key panel.  
Four panels can be connected.

**Note:** *If one or two key panels are used, the optional key panel DBY 409 01 may be used. However, if three or four key panels are used, all optional key panels must be of type DBY 409 02.*

**20 Loudspeaker**

















**21 Handset with hearing aid function**

**Please note:** *The handset may retain small metal objects in the earcap region.*

## Phone keys Dialog 4224 / Dialog 3214





This table gives you an overview of the different key design of the Dialog 4224 Operator and the Dialog 3214. In this user guide you will only find illustrations of the Dialog 4224 keys.

If you are using the Dialog 3214, please refer to the table below to find out the appropriate key combination.

Key	Dialog 4224	Dialog 3214
Answer/extend		
Clear left Speech left		
Clear right Speech right		
Headset		Headset 
Loudspeaker		
Mute		
Programmable Function key		
Volume		

## Lamp indications

The key lamps on your telephone indicate with different signals the traffic state of the ongoing call or function.

	Extinguished lamp	The function is not active.
	Steady light	The function is active.
	Slowly flashing lamp	The line (or function) is put on hold.
	Rapidly flashing lamp	An incoming call or message waiting.
	Light with short breaks	Ongoing call.

## Display info

The display assists your actions on the phone with step-by-step instructions.

The tiltable display consist of 5 rows, with space for 40 characters on each row. The fields in the display consists of the following information.

```

DATE, TIME & TEMP. || SPECIAL INFO
QUEUE INFO          ||
INCOMING CALLS     || OUTGOING CALLS
CALLER INFO        || CALLER INFO
  menu1           menu2           menu3           menu4

```

When your phone is idle, the first (upper) line shows date, time, temperature, name and extension number. The second line presents queue information. The lower line presents the available menu key functions.

```

12 May 10:35 +15°^ || OPERATOR      200
C= 0 I= 0          ||
                   ||
                   ||
  directory  redial                prog

```

During an external outgoing call the third line will show the directory number of the external line and dialled/connected telephone number. The fourth line displays the call type.

```

12 May 10:35 +15°^ ||
C= 0 I= 0          ||
                   || 701      1234567890
                   || EXTERNAL
  save                meter

```

During an internal call the third line will show the extension number and traffic state. The fourth line displays the caller's name.

```

12 May 10:35 +15°^ ||
C= 0 I= 0          ||
                   || 1207      BUSY 0
                   || SMITH
  info

```

If you make an internal call to someone who has activated a diversion, the first and second line shows the name and extension number of the person you called and the third and fourth line shows where the call is diverted.

```
12 May 10:35 +15^*|| 203
C= 0 I= 0      || CHAMBERS DAVID
                || 201      FREE 1
                || BURNES BOBBY
                bypass
```

During an external incoming call the third line will show the directory number of the external line and traffic state. The fourth line displays the caller's telephone number and call type.

```
12 May 10:35 +15^*||
C= 0 I= 0      ||
> 701          SPEECH<||
>123456        NEW<||
directory redial
```

Description

### **Status information**











The status information of incoming and outgoing calls is sometimes given as an abbreviation and sometimes as a complete word:

ABSENT	Radio Paging receiver not in use.
BLOCKED	Number or function blocked.
BUSY	Extension is busy (queue situation is displayed).
COMPLETE	Ordered Paging is completed.
CONGEST.	Congestion in the system, call cannot be put through.
C= 0	Number of calls waiting in the common queue.
DIVERSION, DIV	Call redirected.
FREE 1	Line 1 on called extension is free.
FREE 2	Line 1 on called extension is busy, but Line 2 is free.
I= 0	Number of calls waiting in the individual queue.
ICM	Intercom call.
INCOMPL.	The number was incomplete.
INF%	Voice information activated.
INF&	Text information activated.
INFO	The called extension has text or Voice info stored.
INQUIRY, INQ	Inquiry call.
INTRUSION	Intrusion into ongoing call.
MCID ACCEPTED	Malicious Call Identification accepted.
MCID REJECTED	Malicious Call Identification rejected.
METER, MET	Call charging.
NEWCALL, NEW	Call not previously answered.
RECALL	Recall of previously answered call.
RERO	An external incoming call was rerouted to the operator.
RESTR., REST	Restricted extension, calls cannot be handled.
RING	Ring to announce call.
SERIAL, SER	Serial calls.
SPEECH	Speech connection.
TRF	Transferred call.
VACANT, NU	Non assigned number.
WAIT	Radio Paging waiting.
+15° ^	Indicates outside temperature and tendency (up or down) if your telephone system is equipped with optional temperature sensor.



## Tones

Tones are audible in the handset.

<b>Dial tone</b> (System ready to accept digits)	
<b>Special dial tone</b> (System ready to accept digits, active diversion on telephone)	
<b>Ringling tone</b> (Ringing signal to called party)	 - repeated after 4 s
<b>Special ringing tone</b> (Ringing signal to Line 2)	 - repeated after 4 s
<b>Busy tone</b> (Called party is busy)	
<b>Number unobtainable tone</b> (Called number not accessible or vacant)	
<b>Blocking tone</b> (Call cannot be executed due to congestion or called party blocked)	
<b>Verification tone</b> (Verification that ordered function is accessed)	
<b>Intrusion tone</b> (Sent to all parties during Intrusion)	
<b>Conference tone</b> (Sent to all participants in a Conference)	 - repeated after 15 s

Description

## Signals

Ringing signals are emitted from the phone.

**Internal ringing signal**



- repeated after 4 s

**External ringing signal**



- repeated after 4 s

**Automatic Callback signal**



**Note:** *The tones and ringing signals in this guide refer to the standard system but may vary between countries.*

## Attendance

These features are for re-routing your incoming external calls to an alternative answering position.

### Off Duty

When you activate Off Duty, all incoming external calls to the operator queue will be routed to an alternative answering position.

Off Duty 

#### Activate

**Press to activate.**

The lamp lights. Console is off duty.

Temporary change of alternative answering position is possible:

temp  
○○○  
○○○  
○○○  
○

**Press (see display).**

**Type in the new alternative answering position.**

**Note:** This procedure can only be performed by the last active operator.

ans/ext  

**Press to confirm.**

```
12 May 10:35 +15^*|| OFFDUTY ACTIVATED
C= 0 I= 0          || ANSW.ADDR: 1210
                  ||
                  ||
directory redial   temp     prog
```

**Off Duty** 

**Deactivate**

**Press again to deactivate.**  
The lamp extinguishes. Console attended.

---

**Night Switch**

This function switches the whole system to the Night Switch mode. The Night Switch mode routes all incoming external calls to a defined night answering position e.g. an answering machine.

*Night* 

**Press to activate (pre-programmed)**  
The lamp lights. Night Switch active.

*Night* 

**Press again to deactivate (pre-programmed).**  
The light extinguishes. Night Switch passive.

## Incoming Calls

### **Internal calls**

A ringing signal indicates an incoming call. The display shows the number and the name of the internal caller.

---

### **External calls**

A ringing signal indicates an incoming call. If you are connected to a digital trunk line (ISDN), the display shows the number of the external caller and in case of diversion in the public net the display shows the number of the diverted as well as the calling party, see also section "[ISDN Facilities](#)" on page 81. A trunk line is the same as an external line.

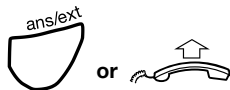

## Answer calls

Either a new call (external or internal) or a recall (recall from hold, from no answer, from Camp-on or a serial call). The left side of the display shows the type of call.

### Press or lift the handset to have speech connection.

If you don't lift the handset the call is in handsfree mode, via the loudspeaker and microphone, or connected directly to your headset (if installed).

```
12 May 10:35 +15^11
C= 0 I= 0      11
> 701        SPEECH11
>123456      NEW11
directory  redial      serial.
```



### Press to end the call.

How to transfer an incoming call, see section “Transfer” on page 36.

## Silent ringing

This function is useful if you do not want to be disturbed by the ringing of the telephone. Incoming calls will only be indicated on the display.

**Note:** For the Dialog 3214 this function requires the release number R5B or higher, see the underside of your telephone.



In idle mode:

### Press to mute the ringer for incoming calls.

## Outgoing Calls

Sometimes you make a call but the person is not available. These functions will help you in your attempts to establish contact with the called party.

---

### Make internal calls

How to make internal calls.



**Dial an extension number or internal group number.**  
The status of the extension is displayed.

**Or:**

Thomas P 

**Press a pre-programmed key.**  
The status of the extension is displayed.

  
**Speech** 

**General handling:**

**Press to call an extension.**

  
**Clear** 

**Press to end a call.**

## Make external calls

How to make external calls.

- 0** **Press the digit(s) for external call access.**  
External dial tone.

**Note:** Which digit to press for external call access, depends on the configuration of the system.

**Or:**

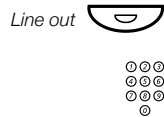

- Press a pre-programmed Line key.**  
External dial tone.

**Dial the external number.**

**Note:** You can make your calls faster, using Common Abbreviated Numbers and by programming your own Abbreviated Numbers.

---

## Last External Number Redial

When you initiate an external call the system automatically stores all the dialled digits, irrespective of whether the call was successful or not. See also section “[Automatic Redial](#)” on page 25.

- \* \* \*** **Press to redial the last dialled external number.**  
The display will show the dialled number.



## Save external number

When you make an external call, you can save the number in order to redial it easily. Previously saved number is erased. The number may consist of up to 24 digits.

### Save number

save

**Press before you finish the call (see display).**

### Redial number

redial

**Press to redial the saved number (see display).**

## Automatic Redial

If you call an external number and receive busy tone or get no answer, you can instruct the system to automatically redial the number until it is available.

This function is activated via Function keys, so you first have to program a programmable key (one key required per number). You can activate Automatic Redial on up to five external numbers at the same time.

### Activate

During the call:

Automatic  
Redial 1



#### **Press to activate (pre-programmed).**

The Automatic Redial lamp is rapidly flashing and is lit when the request is stored and activated. Verification tone.



#### **Replace the handset.**

**Or:**

Clear



#### **Press to finish the procedure.**

You are called back if the called number finishes the ongoing call or the next time the extension finishes a new call. The display shows:

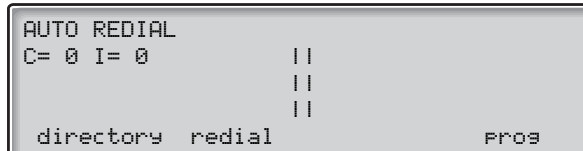

**Lift the handset when you are called back.**

(You can also press the answer/extend key to answer in handsfree mode.)

**Notes:** It is not possible to do a new request on a key holding an already activated request until the existing one is cancelled.

When the Automatic Redial lamp is rapidly flashing, your telephone is busy and you cannot receive or make new calls.

The number of redial attempts and how long the function is active is programmed by your system administrator.

Automatic Redial 1



**Cancel**

**Press the relevant programmable key to cancel the Automatic Redial request (pre-programmed).**

**Note:** Depending on system programming, the Automatic Redial request could be cancelled automatically.

Pause auto redial



**Pause**

It is possible to pause all of your successfully activated requests by programming a separate pause key.

**Press to pause (pre-programmed).**

The requests are paused and the key lamps of the Automatic Redial keys are flashing slowly.

Pause auto redial



**Press to resume Automatic Redial (pre-programmed).**

## Busy extension

An incoming call would like to be transferred to a specific extension, but the called extension is busy. You have several options:

**Note:** You can intrude on a busy extension, see section ["Intrusion and forced release"](#) on page 29.

### Option 1

To transfer the call to the busy extension:

info

**Press and hold (see display).**

The conversation partner of the busy extension, is shown in the display.



**Press to place the call.**

The call will be placed automatically when the extension becomes free. The extension will hear a call waiting signal.

### Option 2

To camp-on the call:

**Notify**

**Press.**

**Loop 1**

**Press any free Loop key.**

The key lamp shows steady light. The call is now in camped on state, with notification of free extension. You can answer new incoming calls.

**Note:** Calls cannot be camped on to internal group numbers.

A ringing signal and the Loop key lamp flashing indicates that the extension is free. Answer within eight seconds by pressing the Loop key, otherwise the call will be placed automatically.

**Loop 1**

**Press.**

The Loop key light extinguishes.

**Speech**

**Press to call the extension.**



**Press to place the call.**

**Or:**

If the caller wants another extension:

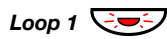

**Press.**



**Press.**

Call the new extension and place the call in the normal way.

**Option 3**

The caller prefers to call again later:

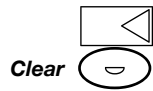

**Press to disconnect.**



**Press to disconnect.**

---

## Diverted extension

This is useful if you have to place an urgent call with or contact an extension that is diverted. You have called an extension with diversion:

**bypass**

**Press (see display).**



**Press to bypass the diversion and call the extension.**

## Intrusion and forced release

If a called extension is busy, you can break into ongoing calls and give new calls priority. To intrude on the busy extension:

info

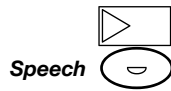

### **Press and hold (see display).**

The conversation partner of the busy extension, is shown in the display.

**Press.**

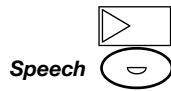

### **Press to intrude.**

A warning tone is heard. Inform the extension of the new call.

**Select option 1 or 2.**

### **Option 1**

The extension accepts the call:

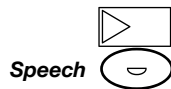

### **Press again.**

The person talking to the extension is disconnected.

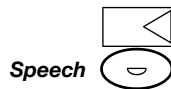



### **Press.**



Speech connection with the caller. Inform the caller.



**Press to place the call.**

**Option 2**  
The extension asks the caller to wait:

**Speech**   **Press.**

**Speech**   **Press again.**  
Speech connection with the caller. Inform the caller.

 **Press to place the call.**  
The call will be placed automatically when it becomes free.

**Note:** *If the Intrusion isn't allowed, ask the caller to call back.*

## Busy external line

If no external line is available for your call:

**Notify** 

**Press.**

**Loop 1** 

**Press any free Loop key.**

The key lamp shows steady light. You can answer new incoming calls.

A ringing signal and the Loop key lamp flashing indicates that an external line is available.

**Loop 1** 

**Press again.**

The Loop key light extinguishes. External dial tone. Continue making the external call.



### Intrusion on a busy external line

You can break into a busy external line.

info

**Press and hold (see display).**

The conversation partner of the busy external line, is shown in the display.

**Speech**  

**Press to intrude.**

A warning tone is heard. Inform the external line of the new call.

**Speech**  

**Press again.**

The person talking on the external line is disconnected.

## Supervise long distance calls

You have dialled an external number and want to handle new calls while you wait for it to be answered.

**Monitor** 

**Press.**

The key lamp shows steady light. The call is supervised. You can answer new incoming calls.

When the long distance call is answered:

**Monitor** 

**Press again.**

The monitor key lamp extinguishes. You have speech connection.

***Note:** If you have an ongoing call, it must first be transferred, camped on or finished, before you can press Monitor.*

---

## Abbreviated Numbers

By using Abbreviated Numbers, you can make calls simply by pressing a few keys. Frequently used external numbers are stored as Common Abbreviated Numbers in the exchange. A total of 71 Individual Abbreviated Numbers (your personal most frequently used external numbers) can be stored and used on the keys A to C on the telephone, and on the key panel keys.

***Note:** Functions that you activate/deactivate via a dial code, e.g. \*32\* and #32# for reminder, can also be stored as Individual Abbreviated Numbers.*



## Common Abbreviated Numbers

External numbers are stored centrally in your BusinessPhone Communication Platform. Common Abbreviated Numbers can be dialled from every extension that has the authority to do so.



**Dial the Common Abbreviated Number.**  
Please refer to your telephone directory.

---

## Individual Abbreviated Numbers

You can program and activate your most frequently used external numbers on the 2nd layer of a programmable key. This procedure can also be used if you want to program a function that is activated/deactivated via a dial code.

2nd

**Press.**

Thomas P

**Press to make a call or activate a dial code (pre-programmed).**

## Dial-by-Name

You can program and activate directory numbers (extensions and Common Abbreviated Numbers) on the programmable keys.

Head Office

**Press to make a call (pre-programmed).**

## Phone Book

You can search for all directory numbers and Common Abbreviated Numbers in the integrated telephone directory.

directory

**Press (see display).**

```

12 May 10:35 +15^*|| OPERATOR      200
C= 0 I= 0           ||
                    ||
internal external          return
    
```

You can choose between *internal* telephone directory that contains all directory numbers, and *external* telephone directory that contains all Common Abbreviated Numbers.

internal

**Press (see display).**

To search in the internal telephone directory.

external

**Press (see display).**

To search in the external telephone directory.

You can press `search` (see display) to step through the whole directory or use the keypad to select the first or more characters of the second name.

```

12 May 10:35 +15^*|| OPERATOR      200
C= 0 I= 0           ||
                    ||
B_
                    search  disconn
    
```

**Note:** How to write text is described in section [“Write Text”](#) on page 92.

search

**Press (see display).**

If the proposal is correct, call the number (see display). If not, use `backward` or `forward` to step through the directory.

## During Calls

The BusinessPhone Communication Platform allows you to handle calls in many different ways. You can switch between handset and handsfree/group conversation, mute the microphones, make an inquiry, transfer the call, create a Conference or put the call on hold to perform other tasks.

---

### Group Listening

You have an ongoing conversation via the handset.



**Press to switch the loudspeaker on or off.**

When the lamp lights, the loudspeaker monitors the call.

---

### From handset to handsfree

You have an ongoing conversation via the handset.



**Press to switch the loudspeaker on.**

You are now in the Group Listening mode.

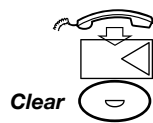

**Replace the handset.**

Handsfree conversation.

**Press to end the call.**

### From handsfree to handset

You have an ongoing handsfree conversation.



**Lift the handset.**  
Conversation via the handset.

---



## Mute

You have an ongoing conversation.

**Press to switch the microphone on or off.**  
When the lamp lights, the caller will not be able to hear the conversation in your room.

---



## Transfer

You want to transfer an incoming call to an extension.

**Dial the extension number or an internal group number.**  
The status of the extension is displayed.

**Or:**



**Press a pre-programmed key.**  
The status of the extension is displayed.

**Select option 1 or 2.**

**Note:** If the extension is busy, see section "[Busy extension](#)" on page 27.

### Option 1

Transfer right away:

**Note:** Make sure, that you are connected to the desired party. Please read the notes and warnings in section "[Useful Hints](#)" on page 100.



**Press.**

**Or:**



**Replace the handset.**

The call is transferred. External calls might only be transferred with the Transfer key, if this state of connection is allowed by the system programming.

**Option 2**

Announce the call first:



**Speech**



**Press to call the extension.**

Announce the call when the extension is answered.



**Press.**

**Or:**



**Replace the handset to place the call.**

**Transfer to a busy extension**

You can even transfer calls to busy extensions. The other party will hear a muted signal (Camp-on), and the call will be extended, as soon as the ongoing call is terminated (if Camp-on is allowed).

**Callback**

You are called back, if you have transferred an external call and the other extension has not answered the call within a certain time. Your telephone will ring again.

## Conference

You have an ongoing conversation and you want to establish a telephone conference.



**Dial the extension number of the third party.**

**Note:** *Is the ongoing conversation partner shown on the right display, then you have to press left Speech before you can call the third party.*

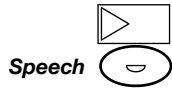

**Press to call the third party.**

When the third party answers:

conf

**Press to establish a three party conference (see display).**  
Conference tone will be sent.

**Select option 1 or 2.**

### Option 1

Finish the Conference:



Depending on which partner you want to disconnect from the Conference, you can press the left or right Clear key.

**Press to finish the Conference.**

**Or:**



**Press to finish the Conference.**

### Option 2

If you want to connect your Conference partners:

extend

**Press to connect (see display).**

**Note:** *Make sure, that you are connected to the desired party. Please read the notes and warnings in section "Useful Hints" on page 100.*

## Individual Hold

Incoming calls can be put on hold for retake. You have speech connection with the caller.

**Loop 1** 



**Press any free Loop key.**

The key lamp shows steady light. The call is put on hold. You can answer new incoming calls or put new calls on hold.

**Loop 1** 

**Press again.**

The Loop key light extinguishes.

**Speech**   

**Press to retake.**

---

## Individual Hold and monitor

Incoming calls can be put on hold for monitoring. You are able to listen to the call on hold.

**Monitor** 

**Press.**

The key lamp shows steady light. The call is put on hold. You can answer new incoming calls.

**Monitor** 

**Press again.**

The monitor key light extinguishes. The call is retaken.

## Operator hold

Several incoming calls can be put on hold using this function.

You have speech connection with the caller.



**Press (pre-programmed).**

The call is put on hold. The key lamp shows a steady light. You can answer new incoming calls and also put calls on hold by pressing the key again during an ongoing call.

When you want to retake one of the calls on hold, you must be free from ongoing calls:



**Press (pre-programmed).**

The oldest call on hold is shown in the display.

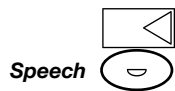

**Press to retake.**

The call is retaken. The Hold key lamp remains lit if more calls are still on hold.

**Or:**



**Press (pre-programmed).**

The call is put on hold again. The next call on hold is shown.

**Repeat until the required call is shown.**

When all calls are retaken the key lamp extinguishes.



## Serial calls

The external caller wants to speak to several extensions in a certain order:

serial

**Press (see display).**



**Call the first extension.**



**Press.**

Inform the extension that he/she will be connected to a serial call which cannot be transferred and the call is rerouted back to the operator if you go on-hook.



**Press to place the call.**

Recall after the first conversation:

**Place the call with the next extension in the normal way and repeat until one requested extension remains.**

Before the last call in the serial call:

serial

**Press (see display).**

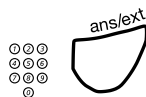

**Call the last extension and press to place the call.**

After the last conversation, the serial call is terminated.

## Call Ordering

These functions allows you to order internal calls, external calls or an external line for other extensions. The ordering extension may or may not remain on line.

---

### Dial tone ordering

An extension calls and orders an external line with dial tone. The caller remains on the line.

**Ask the caller to wait.**

**0**

**Press the digit(s) for external call access.**

External dial tone.

**Or:**

Line out 

**Press a pre-programmed Line key.**

External dial tone.



**Press.**

The ordering extension receives the external line with dial tone.

## Call ordering on line

An extension calls and orders a call to an external or internal party. The caller remains on the line.



### Ask the caller to wait and call the requested party.

The normal way of making an internal or external call. See section “[Outgoing Calls](#)” on page 23.

**Press to place the call.**

## Call ordering off line

An extension calls and orders a call to an external or internal party. The caller does not remain on the line after ordering.



### Call the requested party.

The normal way of making an internal or external call. See section “[Outgoing Calls](#)” on page 23. You can reserve a line for the call, see below.

### Ask the called party to wait.

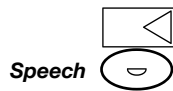

**Press.**



### Call the extension that ordered the call and press.

Announce the call when the extension is answered.



**Press to place the call.**

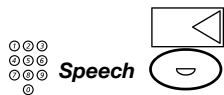

**Reserve a line**

You can key the caller's extension number first and then the requested number in order to reserve one of the caller's lines.

**Call the extension that ordered the call and press.**

The extension will be transferred to the left display and one of the caller's line will be blocked.



**Call the requested party.**

The normal way of making an internal or external call. See sections "Outgoing Calls" on page 23.

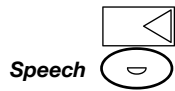

**Ask the called party to wait.**

**Press.**

The ordering extension is called. Announce the call when the extension is answered.



**Press to place the call.**

## Call Metering

When the BusinessPhone Communication Platform is provided with metering information from the public net, the call metering function can be used to check the cost of outgoing calls. The BusinessPhone Communication Platform offers several options to obtain this information.

---

### Cost of the last call

After finishing an outgoing external call, you have the possibility to see the cost of the last call.

**\*46#**



**Dial.**

The display shows the cost of the last call.

**Press to finish the procedure.**

---

### Read out your own cost counter

This is useful, when you want to check the accumulated cost of your own counter.

**\*45#**



**Dial.**

The system shows the accumulated cost since the last reset.

**Press to finish the procedure.**

## Read out cost counter for others

You can read out and reset the cost counters for other extensions and trunk lines. If your system is equipped with a printer you can initiate a printout.

**\*45#**

### Dial.

The system shows the accumulated cost of your own extension since the last reset.

```

12 May 10:35 +15^11
C= 0 I= 0      ||
                ||
OWN COSTS: EUR      50
  other      check      return
    
```

other

### Press (see display).

The system requires a Password.



### Enter the Password.

Ask your system administrator for the defined Password.



**In case of a typing error, press the Volume Down key to delete the latest entered digit.**

activate

### Press to confirm the Password (see display).

Select the type of meter you want to read out.

```

12 May 10:35 +15^11
C= 0 I= 0      ||
                ||
SELECT TYPE OF METER
  caller      trunk      return
    
```

caller

**Press to read out an extension counter (see display).**

If the system is included in a network, you will be able to read out the cost of the tie lines in this menu.

**Or:**

trunk

**Press to read out a trunk line counter (see display).**

```

12 May 10:35 +15^11
C= 0 I= 0      ||
                ||
ENTER DIRECTORY NUMBER:
display  print  reset  return
    
```

○○○  
○○○  
○○○  
○

**Enter the directory number of the desired extension or trunk line.**

(If you do not enter a directory number the accumulated cost of the entire system will be shown.)

return

**Press to return to previous menu (see display).**

reset

**Press to reset counter (see display).**

***Note:** The reset function in this menu is only applicable when a printer is connected to the system. To initiate a reset procedure you require a special authority level (please ask your system administrator if this feature is available on your phone). To avoid different countervalues for total extensions and total trunk lines in the system, we recommend to reset all the extensions and trunk line counters at the same time.*

print

**Press to initiate a printout on the printer (see display).**

This function is applicable when a printer is connected to the system. You also require a special authority level to initiate a printout. For a detailed description of the printout, see section "Printout" on page 49.

display

**Press to show the counter on the display (see display).**

```

12 May 10:35 +15*^||
C= 0 I= 0      ||
              ||
COST 201: EUR      50
              print   reset   return
    
```

In this menu you have the same possibilities as in the previous menu. It is also possible to reset without a printer.

If you have not entered a specific directory number in this procedure, you will see the accumulated cost of the entire system.

```

12 May 10:35 +15*^||
C= 0 I= 0      ||
              ||
200-200: EUR      300
              detail   return
    
```

detail

**Press to read out the detailed counters of each extension/trunk line (see display).**

In this menu you have the same possibilities as in the previous menu for reading out a single counter.

```

12 May 10:35 +15*^||
C= 0 I= 0      ||
              ||
COST 200: EUR      20
              next    print   reset   return
    
```

next

**Press to step through all the counters (see display).**



**Press to finish the procedure.**



## Printout

The printout covers the following information:

*Example:*

<i>Call Metering Information BusinessPhone</i>				
<i>Date: 03 05 12</i>		<i>Time: 10:53</i>		
<i>Aastra Telecom Sweden AB</i>				
<i>LM Ericssons väg 30</i>				
<i>SE-126 37 Hägersten</i>				
<i>Sweden</i>				
<i>Reason for print out : Read</i>				
<i>Division : Total system</i>				
<i>Group : Callers</i>				
<i>Directory number range : 4736</i>				
<i>Currency : EUR</i>				
<u><i>Dir. No.</i></u>	<u><i>Name</i></u>	<u><i>Pulses</i></u>	<u><i>Cost</i></u>	<u><i>Cost/Pulse</i></u>
<i>4736</i>	<i>Mr.Plattner</i>	<i>76</i>	<i>38.00</i>	<i>0.50</i>
<i>Total</i>		<i>76</i>	<i>38.00</i>	

**Printout contents**

<b>Date:</b>	Shows the date of the printout.
<b>Time:</b>	Shows the time of the printout.
<b>Aastra Telecom Sweden AB LM Ericssons väg 30 SE-126 37 Hägersten Sweden</b>	4 lines with 50 characters per line are free for definition. For example, for the company address.
<b>Reason for print out:</b>	This field shows if the printout was initiated only to read out the counter or if the printout was caused because of a reset procedure.
<b>Division:</b>	This field is prepared for future applications. Currently it always shows <i>Total system</i> .
<b>Group:</b>	Shows if the desired directory number(s) is (are) related to the extension (caller) or trunk group.
<b>Directory number range:</b>	Shows the directory number of the desired extension or trunk line. When no directory number is entered then <i>ALL</i> will be shown in this field and you will see all the counters of the extensions and trunk lines on the display.
<b>Currency:</b>	Shows the defined currency.
<b>Dir.No.:</b>	Shows the directory number of the desired extension/trunk line.
<b>Name:</b>	Shows the name of the extension or trunk line.
<b>Pulses:</b>	Shows the accumulated pulses for the desired extension/trunk line since the last reset.
<b>Cost:</b>	Shows the accumulated cost for the desired extension/trunk line since the last reset.
<b>Cost/Pulse:</b>	Shows the actual price per pulse.
<b>Total:</b>	Shows the accumulated pulses and cost of all the extensions/trunk lines on the printout.

## Integrated System Check

To avoid a loss of the counter values during reconfigurations of the system, an Integrated System Check offers you the opportunity to read out all the counters which were not reset before the reconfiguration. To initiate the System Check you need a special authority level (please ask your system administrator if this feature is available on your phone).

\*45#

**Dial.**

(Same procedure as used for reading out accumulated cost.)

```
12 May 10:35 +15^*11
C= 0 I= 0      ||
                ||
OWN COSTS:      20 EUR
other   check   return
```

check

**Press to initiate a system check (see display).**

When a fault is found the following information will be shown:

```
12 May 10:35 +15^*11
C= 0 I= 0      ||
                ||
CALLER RECORD FAULTY
display        return
```

display

**Press to display the fault records (see display).**

The display shows the first fault record in the system. The display information includes the extension numbers which have been deleted during the reconfiguration and the related cost for these extensions.

```
12 May 10:35 +15^*11
C= 0 I= 0      ||
                ||
202      EUR      50.00      COSTS
next    cost/pulse  reset    return
```

next

**Press to step through the faulty records (see display).**

cost/pulse

**Press to toggle between the indication in pulses or cost (see display).**

reset

**Press to reset the faulty record (see display).**  
In this case no printout will be initiated to the connected printer.

return

**Press to return to previous menu (see display).**

## Operator supervised call

An extension can order an external call to be metered. The caller can remain on the line or hang up (off line) while you establish the call.

### Option 1

Registration on the callers individual call meter:

#### **Set up the external line.**

See section "[Make external calls](#)" on page 24.

External dial tone.

```
12 May 10:35 +15^11
C= 0 I= 0      ||
> 701          SPEECH<|| 207      FREE 1
>123456        MET<|| SMITH
                save              meter
```

meter

**Press (see display).**  
Continue setting up the external call, see section "[Call Ordering](#)" on page 42.

Recall after the call is terminated:

#### **Press.**

The display informs about call duration, number of pulses or cost (depending on the configuration). Note the information.

```
12 May 10:35 +15^11
C= 0 I= 0      || SMITH
 701          RECALL || DURATION 00.00.50
                MET || PULSES      3
```

If you want to register the cost information:





**Press again.**

The call is registered on the callers individual call meter.



**Clear**



**Press to disconnect the call.**

**Option 2**

Registration on a specified Account Number:

*Account*



**Press (pre-programmed).**



**Dial the Account Number.**

*Account*



**Press again (pre-programmed).**

Continue setting up the external call.

## Call Forwarding

You may be the answering position for calls that are diverted from the extensions in the office.

---

### Change diversion address for another extension

As an operator you have the possibility to change, activate or cancel the diversion address for another extension, for example when someone is ill and wants his calls to be answered by another person. You can control both Internal and External Diversions.

**Note:** *A blocked extension will be bypassed.*

#### Change and activate Internal Diversion

To change and activate a programmed Internal Diversion.

**\* 2 1 \***

**Dial.**

⦿⦿⦿  
⦿⦿⦿ \*  
⦿

**Dial the extension number and press.**

⦿⦿⦿  
⦿⦿⦿  
⦿

**Enter the new diversion address.**

**#**

**Press to activate the Individual Diversion.**  
Verification tone.



**Press to finish the procedure.**

**Note:** An Individual Internal Diversion cannot be activated if an Individual External Diversion is already activated.

**Cancel Internal Diversion**

**# 2 1 \***

**Dial.**



**Dial the extension number and press.**

The programmed Internal Diversion is deactivated.



**Press to finish the procedure.**

**Program and activate a new External Diversion address**

To set a new Individual External Diversion address:

**\* 2 2 \***

**Dial.**



**Dial the extension number and press.**



**Dial the digit(s) for external call access and enter the new External Diversion address.**

A maximum of 24 digits.

**Note:** If your public network requires waiting for a second dial tone, press \*.

**#**

**Press to activate the Individual Diversion.**

Verification tone.



**Press to finish the procedure.**

**Note:** Call the extension to check if the External Diversion has been set up correctly. This way you can make sure that the number has been programmed properly and that the calls will not be diverted to another person by mistake.

**Cancel External Diversion**

# 2 2 \*



**Clear**



**Dial.**

**Dial the extension number and press.**  
The programmed External Diversion is deactivated.

**Press to finish the procedure.**

*Note: The programmed diversion address is not removed from the memory, the diversion is just inactive.*

**Re-activate External Diversion**

To activate a programmed External Diversion.

\* 2 2 \*



**Clear**



**Dial.**

**Dial the extension number and press.**

**Press to finish the procedure.**



## Absence Information

You can insert Text or Voice information for any extension in the system. This is useful for keeping the stored information up-to-date for colleagues who are out of their offices.

Absence Information can be of three kinds:

### 1) Pre-defined texts

Enter the reason for the absence and the date and time of return.

### 2) Voice information

Record a Voice message and name the reason for the absence.

### 3) Free text information (only to display phones)

Activate a personal text.

---

## Enter information

In order to enter information, you first have to select the address (extension number).

Info 

Press.

```

12 May 10:35 +15^11 OPERATOR      200
C= 0 I= 0           ||
                        ||
ABSENCE INFORMATION FOR:          200
                        leave      chnse-no.
  
```

chnse-no.

**Press (see display).**

The info lamp shows a steady light. This function may not be allowed, please ask your system administrator.



**Dial the extension number.**

activate

**Press (see display).**

leave

**Press (see display).**

absence

**Press to activate (see display).**

You can now register information on the extension.

```

12 May 10:35 +15^11 OPERATOR      200
C= 0 I= 0           ||
                    ||
ABSENCE INFORMATION FOR:          207
      pre-text      voice free-text
    
```

**Select Pre-defined text, Voice or Free text information.**

***Pre-defined texts***

You have selected the address.

pre-text

**Press (see display).**

```

12 May 10:35 +15^11 OPERATOR      200
C= 0 I= 0           ||
                    ||
1 TIME OF RETURN      BACK          HHMM
  activate next-info          return
    
```

next-info

**Select appropriate info using next-info (see display).**



**Enter Completing Info from the table below.**

	Code	Completing Info
Time of return	1	hour (00-23) minute (00-59)
Date of return	2	month (01-12) day (01-31)
Lunch	3	back at, hour minute
Meeting	4	back at, hour minute
Vacation	5	back, month day
Illness	6	back, month day



**In case of a typing error, press the Volume Down key to delete the latest entered digit.**

activate

**Press (see display).**

The programmed absence info will be shown in the display. Internal callers receive the information on the display (or as spoken information to callers without display phone).

Info 

**Press to finish the procedure.**

*Pre-defined texts example:*

*Vacation, back June 27*

pre-text

**Press (see display).**

next-info

**Select appropriate info using next-info (see display).**

```

12 May 10:35 +15^11 OPERATOR 200
C= 0 I= 0      ||
                ||
5 VACATION    BACK      MMDD
activate next-info      return
  
```

**0627**

**Enter month and day.**

activate

**Press (see display).**

Information active.

### Voice information

You have selected the address.

voice

**Press (see display).**

After a short tone the recording starts.

```

12 May 10:35 +15^11 OPERATOR 200
C= 0 I= 0      ||
                ||
RECORDING      020
record  play-back  pause  activate
  
```

- record** **Press and speak (see display).**
- play-back** **Press to play-back and listen to your recording (see display).**
- pause** **Press to pause the recording (see display).**
- activate** **Press to activate the recording (see display).**  
Internal callers will hear the information via the handset or the loudspeaker.
- Info**  **Press to finish the procedure.**

### Free text information

You have selected the address.

**Note:** *Free text information will only be seen by display phones.*

- free-text** **Press (see display).**
-  **Enter the text and press to store the information.**  
Information stored. The complete information is shown constantly on the extension. Internal callers receive the information in the display.
- Note:** *How to write text is described in section "Write Text" on page 92.*

**Info**  **Press to finish the procedure.**

---

## Change information

- Info**  **Press.**
- change-no.** **Press (see display).**  
The info lamp shows a steady light. This function may not be allowed, please ask your system administrator.



**Dial the extension number.**

```
12 May 10:35 +15^*|| OPERATOR      200
C= 0 I= 0           ||
                ||
ABSENCE INFORMATION FOR:           207
erase      leave      off  chnse-no.
```

**Erase**

- erase**                    **Press (see display).**
- absence**                **Press to erase the information (see display).**

**Change**

- leave**                    **Press to leave another information (see display).**
- Or:**
- on/off**                  **Press to activate/deactivate information (see display).**

**Receive information for diverted calls**

You have answered a call that is diverted to you. Information is registered on the extension.

- div-info**                **Press and hold (see display).**  
The information is shown. Inform the calling party.

```
12 May 10:35 +15^*|| 1 TIME OF RETURN
C= 0 I= 0           || BACK      17:30
> 207      SPEECH||
>CHAMBERS      DIV||
directory bypass      div-info
```

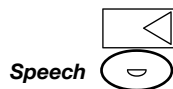

If there is Voice information, you will hear it.

- Press.**  
Inform the caller. You can place or disconnect the call.

## Messages

By using the Message system you can send, receive, forward and store different kind of messages. You have also access to a number of helpful features like placing external calls via the company network and many more ...

---

### Password protection

The first time you enter the Message system (only possible from your own extension) you might be requested to change your Password if it is default (0000).

**Note:** Some systems are programmed to allow the Default Password.

```
12 May 10:35 +15^11 OPERATOR      200
C= 0 I= 0                ||
                          ||
FIRST MBX USE-ENTER NEW PASSWORD:
```



**Enter your new Password and press.**

If you use the Default Password, you are requested to try again.



**Enter your Password again and press.**

The new Password is saved.



**Press to finish the procedure.**

**Or:**

**Continue with any of the Message functions.**

If you want to change your Password again, see section "[Change Password](#)" on page 73.

## Common Mailbox system

If you divert your telephone to a Common Mailbox, the callers are able to leave messages there.

### Activate

Divert your extension to the Mailbox system.

**Off Duty** 

**Press.**

TEMP

**Press (see display).**



### **Dial the Common Mailbox number.**

Please ask the system administrator for your defined Mailbox number.

*Note: This procedure can only be performed by the last active operator.*



When the diversion to your Mailbox is activated, the Off Duty lamp shows steady light.

**Press to confirm.**

### Deactivate

**Off Duty** 

**Press.**

The lamp extinguishes.

### Retrieve messages - internally

Common Mailbox 

**Press the Common Mailbox key (pre-programmed).**



**Speech** 

**Press to connect.**

During the procedure you will be asked for your extension number and your Password. See section "Security" on page 73.

### **Retrieve messages - externally**

To retrieve your messages from an external position:



**Dial your company's telephone number.**



**Dial the Common Mailbox number.**

During the procedure you will be asked for your extension number and your Password.

**Note:** *You cannot use the Default Password 0000 to retrieve messages externally. If you want to check your messages from an external position, you have to change your Password first, see section "Change Password" on page 73.*

The following Mailbox functions can also be used from an external position:

- Change Password
- Check and store received messages
- Forward a Voice message
- Send Message

### **Check and store received messages**

You can check and store your received messages.

Received messages are divided into the following three categories:

- New messages (not heard or read)
- Heard/Read messages
- Stored messages

Voice messages can also be forwarded to other Mailbox numbers (Individual or Common), see section "Forward a Voice message" on page 70.

**Note:** *Messages are deleted from the system after a certain time. The time depends upon the category of the message. Please ask your system administrator regarding this.*



**Press to view Mailbox.**

If the Mailbox contains heard messages only, the lamp shows steady light instead.



**Note:** Depending on the configuration, you might be asked for your Password before you can retrieve your messages. See section "Security" on page 73.

receive

**Press (see display).**

```

12 May 10:35 +15^11 OPERATOR 200
C= 0 I= 0      ||
                ||
MESSAGE      3      2      12
return      new      heard      stored
    
```

new

**Select message category (see display).**

New, heard, read or stored.

call-back

**Select message type (see display).**

**Note:** If only one message type is available (Callback, Voice or Text messages), this step is excluded. If an internal caller has left a message, the name and number is displayed. In case of an external caller, you can see the number, if this feature is provided by the network.

**Use the menu keys to check the message (see display).**

Voice messages will be heard via the speaker or the handset.

Call Me messages will call the sender automatically.

Text messages are read in the display.

Select one of the following options:

next

**Press to check the next message (see display).**

erase

**Press to erase the message (see display).**

store

**Press to store the message (see display).**

Up to 20 messages can be stored. Callback messages cannot be stored.

Message 

**Press to finish the procedure.**

## Send Message

You can send a message without calling an extension (direct message) or when you call an extension and receive busy tone or get no answer.

Message   
send

### Direct message

**Press.**

**Press (see display).**

```
12 May 10:35 +15^*|| OPERATOR      200
C= 0 I= 0                ||
                        ||
FROM NUMBER:   200  TO NUMBER:
send  chnse-no.      chnse-no.
```

○○○  
○○○ send  
○

**Dial the extension number and press (see display).**

```
12 May 10:35 +15^*|| OPERATOR      200
C= 0 I= 0                ||
                        ||
FROM NUMBER:   200  TO NUMBER:   201
call-back     voice    text
```

call-back

**Select message type (see display).**

**Note:** After sending, you can repeat to other extensions. You can also change the sending extension number, if you want the message to be sent from someone else (if this function is allowed). Please ask your system administrator if you require this function.

Message 

**Press to finish the procedure.**

The message is sent. The Message lamp extinguishes.

**During an unanswered call**

When you call an extension and receive busy tone or get no answer, you can send a Callback, Voice or Text message.

Message 

**Press.**

```

12 May 10:35 +15^*|| OPERATOR      200
C= 0 I= 0           ||
                ||
FROM NUMBER:   200  TO NUMBER:   201
              call-back  voice    text
    
```

**Select message type (see display).**

*Note: After sending, you can repeat to other extensions.*

**Callback**

call-back

**Press to send a Call Me message (see display).**

**Voice**

voice

**Press to send a Voice message (see display).**

**Use the menu keys to record your message and send it (see display).**

See section "[Absence Information](#)" on page 57.

**Text**

text

**Press to send a Text message (see display).**

Only available on display phones. See section "[Write Text](#)" on page 92.

Message 

**Press to finish the procedure.**

The message is sent. The Message lamp extinguishes.

## Repeat message

You can easily send the same message to several destinations. When the message is sent, the display shows:

```
12 May 10:35 +15^*|| OPERATOR 200
C= 0 I= 0 ||
||
MESSAGE IS SENT. REPEAT TO ANOTHER ?
yes no
```

**yes**

**Press to select a new message (see display).**

○○○  
○○○  
○○○  
○

**Enter the new extension number.**

**send**

**Press to send the message (see display).**

Repeat the procedure to send the message to the next destination.

**Message** 

**Press to finish the procedure.**

## Change sending extension

When you have dialled the receiving extension number, you can define another extension as sender. The display shows:

```
12 May 10:35 +15^*|| OPERATOR 200
C= 0 I= 0 ||
||
FROM NUMBER: 200 TO NUMBER: 205
send chnse-no. chnse-no.
```

**chnse-no.**

**Press (see display).**

The second Function key from the left (F2).

○○○  
○○○  
○○○  
○

**Enter the new extension number.**

Continue sending the message.

## Check sent messages

You can check messages that you have sent, for instance if you want to erase a message. You can also check messages received at other extensions (not allowed by default, ask system administrator).

Message   
 administr  
 check

**Press.**

**Press (see display).**

**Press (see display).**

```

12 May 10:35 +15^11 OPERATOR      200
C= 0 I= 0           ||
                ||
CHECK MESSAGES - OWN OR OTHERS ?
return           own      others
  
```

### Own messages

OWN

**Press to check your own messages (see display).**

Enter the receiving extension number. You can check and erase the messages that you have sent (see display).

### Others

others

**Press to check messages for another extension (see display).**

Enter the receiving number that you want to check. All messages will be presented with senders name. You can check and erase the messages (see display).

Message 

**Press to finish the procedure.**

## Forward a Voice message

Your received Voice messages (in the Common Mailbox) can be forwarded to other Mailbox numbers (Individual or Common). When you forward a Voice message to an Individual Mailbox, the Mailbox number is the same as the extension number.

**Note:** Returned messages cannot be forwarded.

Message 

**Press to view the Mailbox.**

**Note:** Depending on the configuration, you might be asked for your Password before you can retrieve your messages. See section "Security" on page 73.

receive

**Press (see display).**

new

**Select message category (see display).**

New, heard or stored.

voice

**Press (see display).**

```

12 May 10:35 +15*^|| OPERATOR      200
C= 0 I= 0           ||
                    ||
OPERATOR                200
  play      next      erase      >>>
    
```

>>>

**Press (see display).**

forward

**Press (see display).**

```

12 May 10:35 +15*^|| OPERATOR      200
C= 0 I= 0           ||
                    ||
FORWARD TO:
          forward                chnse-no.
    
```

○○○  
○○○  
○○○  
○

**Dial the Mailbox number to which you want to forward the message.**

forward

**Press (see display).**

The message is forwarded.

**Note:** The forwarded message is a copy, i.e. it can be deleted without deleting the original message.

**Repeat the procedure to forward the message to another Mailbox.**

**Message** 

**Press to finish the procedure.**

## Returned messages

Messages that have been left unanswered for a long period are sent back to you. To check returned messages:

**Message** 

**Press.**

```

12 May 10:35 +15^11 OPERATOR      200
C= 0 I= 0           11
                11
SELECT FUNCTION
  send      receive  administr sent-back
    
```

sent-back

**Press (see display).**

**Use the menu keys to check returned messages (see display).**

You can erase or re-send the message.

**Message** 

**Press to finish the procedure.**

## Dictaphone function

If you want to record and retrieve personal Voice messages you can use the Dictaphone function. A Dictaphone message is treated as a normal message. How to retrieve Dictaphone messages, see section “[Check and store received messages](#)” on page 64.

### Record message

To start the recording:

**\*58#**

#### **Dial and record your message.**

The maximum recording time is 4 minutes and 15 seconds.

```
12 May 10:35 +15^11 OPERATOR 200
C= 0 I= 0      ||
                ||
RECORDING
record play-back pause activate
```

Select one of the following options:

- |           |  |
|-----------|--|
| PAUSE     | <b>Press to pause the recording (see display).</b>                     |
| play-back | <b>Press to play-back (see display).</b>                               |
| record    | <b>Press and speak to re-record (see display).</b>                     |
| activate  | <b>Press to stop the recording and save the message (see display).</b> |



## Security

You can use your four-digit Password for blocking your phone from unauthorized use, for making external calls from any blocked extension, for entering the Message system or when you are using the DISA function.

**Note:** The first time you enter the Message system you might be requested to change your Password if it is default (0000). This procedure is performed directly in the Message system. See section "Messages" on page 62.

### Change Password

# \* 7 2 \*

**Dial to select a new Password.**

0000  
0000  
0000  
0

**Dial your present Password.**

The Default Password is 0000.

\*

**Press.**

0000  
0000  
0000  
0

**Dial your new Password.**

#

**Press.**

Verification tone.

```
12 May 10:35 +15^||
C= 0 I= 0      ||
                ||   #*72*-----*1234#
                ||
```



Clear



**Press to finish the procedure.**

## Bypass blocked extension

In order to make a call, you can temporarily bypass a blocked extension.

### Bypass own extension

\*72\*  
○○○  
○○○  
○○○  
○

**Dial.**

**Dial your Password.**

#

**Press**

Dial tone. You can make one call from your extension.

### Bypass another extension

This makes it possible to make a call on another, blocked extension, by using your Password.

\*72\*  
○○○  
○○○  
○○○  
○

**Dial.**

**Dial your Password.**

\*

**Press.**

○○○  
○○○  
○○○  
○

**Dial your extension number.**

#

**Press.**

Dial tone. You can make one call from the blocked extension.

## Block extension

**\*72#**

**Dial to block your extension.**  
Verification tone.



**Press to finish the procedure.**

### Un-block extension

**#72\***

**Dial.**



**Dial your Password.**

**#**

**Press to re-open.**  
Verification tone. Your extension is open for use.



**Press to finish the procedure.**

## Group Features

When you are working together in a team the following group features can be very useful. You can page your colleagues, give them Telephone Attendance or pick-up their incoming calls.

---

### Key system

With this function, all (or selected) external lines are represented by pre-programmed keys on all phones. For each external line, a Function key has to be programmed. Which means that you are able to monitor the state of traffic for every programmed external line (e.g. free, busy). You can also establish an external call by pressing the External Line key.

#### **Answer an external call**

To answer an external call, just press the flashing key. (Depending on the programming of the system, an incoming external call will be announced with a flashing Line key and a ringing signal).



#### **Press (pre-programmed).**

Speech connection with the caller.

#### **Make an external call**

To initiate an external call, just press the External Line key. The external line will be seized automatically.



#### **Press a free Line key (pre-programmed).**



#### **Dial the desired number.**

If you make external calls in this way, you do not have to dial the digit(s) for external call access first.

## Supervision/Telephone Attendance

A Function key can also be programmed for Supervision and handling calls for a group of extensions. If a Supervision/Attendance key is programmed on your telephone, you are able to call the other group members or answer incoming calls for the group by pressing the key and monitor the activity of other extensions (free, busy, called).

### Traffic situation

Michael 

**Ongoing conversation (lamp is on).**

Michael 

**Free extension (lamp is off).**

Michael 

**The extension is called (flashing lamp).**

### Pick-up calls for the group

Your colleague's extension is indicated on your phone by a pre-programmed key.

Michael 

**Press to answer the calls directly (pre-programmed).**

A flashing lamp beside the key indicates an incoming call.

### Call a group-member

Michael 

**Press to make a call (pre-programmed).**

**Note:** *If the key is flashing, you will automatically pick-up your colleague's ongoing call.*

## Loudspeaker Paging

You can page all extensions in a group and give a Voice message.



**Press (pre-programmed).**

All extensions in a group are called.



**Press again and hold the key (pre-programmed).**

Give the Voice message and then release the key. You can now wait for answer, or terminate. If you do not get an answer within 30 seconds, the Paging function will be terminated automatically.

### Answer Paging

A short signal and a flashing Paging key will inform you when a Loudspeaker Paging is received.



**Press (pre-programmed).**

An internal call is established with the paging party.

---

## Common Bell

The Common Bell feature allows all extensions of the system (operator included) to pick-up the call from an extension that has been predefined as a Common Bell extension.



**Dial the Common Bell pick-up code.**

Please ask your system administrator for the Common Bell pick-up code.

You will immediately be connected to the calling party. If two or more extensions simultaneously attempt to answer a call from the Common Bell extension, only the first extension will pick it up. The other extensions will receive the number unobtainable tone and their displays will show the message No call waiting at Common Bell. This will also happen if you dial the Common Bell pick-up code and there are no calls waiting at the Common Bell extension.

**Note:** *You can also program the Common Bell code on a Function key.*

## Group Hunting

Your telephone can be included in one or several hunt groups. In a hunt group all members are represented with one common directory number. 16 hunt groups can be programmed, each containing 1 to 20 members. A member can be either an extension number, an operator console or a fictive number. Please ask your system administrator if you require this function.

**Note:** *The number of cordless extensions in a hunt group are limited to eight (including Tandem configurations).*

Incoming calls to the hunt group are directed to free extensions in the group. The hunt order within the group can be changed to suit your needs. If all members of the hunt group are busy, an incoming call is being queued. If no one answers this call before the programmed time, the call is forwarded to the programmed answering position (e.g. operator).

**Note:** *If all members in a hunt group are busy, the Callback or Intrusion function is not available.*

### Log in

Before you can answer Group Hunting calls, you must log in.

To log into one hunt group:

**\* 2 8 \***

**Dial.**



**Dial the hunt group code.**

Please ask your system administrator for the configured number.

**#**

**Press.**

To log into all hunt groups:

**\* 2 8 \***

**Dial.**

**\* #**

**Press.**

Answer calls

Answer Group Hunting calls in the normal way.

Log out

To log out from one hunt group:

**# 2 8 \***

**Dial.**



**Dial the hunt group code.**

Please ask your system administrator for the configured number.

**#**

**Press.**

*Note: If you are logged into more than one hunt group and log out from one of them, the display will show the following text:*

```
12 May 10:35 +15^11
C= 0 I= 0      11
                11
LOGGED OUT FROM AT LEAST ONE PBX GROUP
directory redial      temp      prog
```

To log out from all hunt groups:

**# 2 8 \***

**Dial.**

**\* #**

**Press.**



## ISDN Facilities

This chapter is only relevant when your system is connected to a digital trunk line (ISDN-trunk line). It provides a general view of all the (supplementary) services available from the public net which are supported by the system. The services from the public net differ from market to market. Please ask your system administrator which features are available.

---

### Number Identification

The main difference compared to the analog public net is the Number Identification between the connected parties.

```
12 May 10:35 +15^11
C= 0 I= 0      11
> 745        SPEECH<11
>01811004736 NEW<11
directory redial serial
```

When you establish an outgoing external call, the public number of your system and your extension number will be sent to the called party. If the number of the answering party is different from the dialled one (for example, after a diversion), you will also be informed about the answering party's number.

When you answer an incoming external call on your phone (or from another phone), you will see the caller's number on the display. Your public number will be sent to the caller.

## Answer an incoming call from an ISDN-line

A ringing signal and a flashing lamp indicate an incoming call, answer the call in the normal way. One of the following four cases will occur.

### Example 1:

The public net provides the number of the caller.

Mr. Plattner with public number 0 181100 4736 is calling.

```
12 May 10:35 +15^*||
C= 0 I= 0      ||
> 745          SPEECH<||
>01811004736  NEW<||
directory redial serial
```

### Example 2:

The caller has activated Number Secrecy. (The calling number will be suppressed.)

```
12 May 10:35 +15^*||
C= 0 I= 0      ||
 745          NEWCALL ||
DISPLAY REST  NEW<||
directory redial serial
```

### Example 3:

The public net cannot provide the calling number, in this case the normal number of the external line will be shown.

```
12 May 10:35 +15^*||
C= 0 I= 0      ||
 745          NEWCALL ||
EXTERNAL      NEW ||
directory redial serial
```

## Make an external call on an ISDN-line

Establish an external call in the normal way.

If the called party is also connected to a digital trunk line, your public number is shown on the called party's display.

If the connected party number differs from the dialled one (for example: Diversion or Pick-up from another extension), your display shows the new number.

### Example:

Called Party number 0 181100 Extension 4736

```

12 May 10:35 +15^*||
C= 0 I= 0          ||
                  || 738   RING FREE
                  || 01811004736
                save          meter

```

The desired extension 4736 will be answered by extension 5446.

```

12 May 10:35 +15^*||
C= 0 I= 0          ||
                  ||> 738   SPEECH<
                  ||>01811005446 <
                save          meter

```

When the connected party has activated Number Secrecy (number suppression), your display shows the following information.

```

12 May 10:35 +15^*||
C= 0 I= 0          ||
                  ||> 738   SPEECH<
                  ||>DISPLAY REST <
                save          meter

```

## Malicious Call Identification

If you are disturbed by malicious external incoming calls, you can request a number tracing from the network provider.

If you cannot see the number of the caller or connected party (because of an activated number suppression), you have the possibility to register the number in the public network during the call.

Malicious Call ID. 

**Press to register the connected number (pre-programmed).**

**Or:**

**\*39#**

**Dial to register the connected number.**

If the function is accepted in the public net, your display shows the following information.

```
12 May 10:35 +15^11
C= 0 I= 0      11
> 701      SPEECH<11
>MCID ACCEPT NEW<11
directory  save      serial
```

If you cannot identify the connected party, your display shows the following information.

```
12 May 10:35 +15^11
C= 0 I= 0      11
> 701      SPEECH<11
>MCID REJECT NEW<11
directory  save      serial
```

After 3 seconds the display will revert to the previous state.

## Number Secrecy

By pressing a pre-programmed Number Secrecy key you can choose not to show your complete number (public + extension number) to the connected party.

```

12 May 10:35 +15^11
C= 0 I= 0      ||
                ||> 738      SPEECH<
                ||>DISPLAY REST  <
                save      serial  meter
  
```

Number Secrecy



**Press a pre-programmed key to suppress your complete number to the public net.**

The lamp beside the key shows a steady light and the function remains activated until the key is pressed again.

## Other Useful Features

By using these features your productivity will be increased, e.g. you can set reminders for important meetings, place the cost for external calls on separate accounts, listen to music via the loudspeaker and much more ...

---

### Reminder

The phone can be set to remind you at any time within the next 24 hours (multiple settings are allowed).

**\*32\***



**Dial.**

**Dial reminder time.**

(00-23) hour + (00-59) minute. Example: 1430.

```
12 May 10:35 +15^11
C= 0 I= 0      11
                11      *32*
REMINDER TIME 1430
activate clear
```



activate

**Note:** *If you receive busy tone, your extension does not have the authority to set a reminder.*

**In case of a typing error, press the Volume Down key to delete the latest entered digit.**

**Press to activate (see display).**



**Press to finish programming.**

When the reminder time is reached, your phone rings with recall signal.

**Cancel reminder**

**# 3 2 #**

**Dial to cancel all settings.**



**Press to finish the procedure.**

---

## Background Music

You can listen to Background Music over the loudspeaker on your phone by pressing a pre-programmed Music key, or by entering the number for the music channel. Please ask your system administrator for the configured number.

*Background Music* 

**Press to activate the music (pre-programmed).**

The music automatically switches off when you make or receive calls and switches on again when the call is finished.



**Press to cancel the music.**

## Doorphone

The Doorphone is used to monitor the admission to your company, i.e you can open the doorlock from your phone.

Doorphone 

### Answering Doorphone calls

**Press (pre-programmed).**

You will be in speech connection with the calling party.

### Opening of the doorlock

After you have answered the Doorphone, you can open the door by dialling the door-opener's directory number.



**Dial the door-opener's directory number.**

Please ask your system administrator for the number.

---

## Intercom Line

A two-way direct call function between two extensions, for instance in executive-secretary communication.

Intercom  
Secretary



**Press (pre-programmed).**

Speech



**Press to establish an Intercom call.**

Clear



**Press to cancel the Intercom call.**



## Direct Inward System Access (DISA)

If you are working externally and you have the need to make business calls, call your company and use the company PBX to make an external call to the desired party. You just pay the cost for the phone call to your company. The other cost will automatically be placed on your extension number or on a special project.

**Note:** To activate this function, you have to change the Default Password from 0000 to a personal one. Which code to use and how to change it, see section [“Change Password”](#) on page 73.

During the procedure you will be prompted for your Password.



**Dial the public number of your company,**



**followed by the DISA number.**

Ask the system administrator for the defined DISA number.

**Note:** If want to register the call on an Account Number, you should use the Account Number procedure before you enter the external number, see section [“Account Number”](#) on page 90.



**Dial the external number.**

## Account Number

You can place the cost for external calls on a selected Account Number (up to 15 digits). The Account Number can be used *before* or *during* the call.

✳ 9 ✳

**Dial.**

This code cannot be entered during the call.

**Or:**

Account Number



**Press (pre-programmed).**



**Enter Account Number and press.**

Valid digits 0-9.

---

## Automated Attendant

The Automated Attendant facility sends voice instructions to external and internal callers, informing them of all possible options they can choose. Voice instructions lead the callers step by step to the desired destination.



**Dial the Automated Attendant directory number.**

Please ask your system administrator for the Automated Attendant directory number.

## Least Cost Routing

Least Cost Routing (LCR) automatically selects the cheapest way to establish the connection to the desired external number. Please ask your system administrator if this function is installed in your system.

If the extension has been configured to use LCR, each external call will be analysed and the cheapest routing will be selected.

### Use Least Cost Routing



**Dial the digit(s) for external call access and the external number.**

The usual way of making an outgoing external call.

### Calling Least Cost Routing

If LCR has been installed in your system, but your extension is not configured to use it automatically, you also have the opportunity to get the cheapest connection by dialling the LCR code before you dial an external number.



**Dial the LCR code.**

Please ask your system administrator for the LCR code.



**Dial the digit(s) for external call access and the external number.**

***Note:** You can also program the LCR code on a function key.*

## Write Text

It is necessary to write text, e.g. when you are typing Absence Information, sending a Text message or searching the integrated telephone directory. Use the keypad to write text, e.g. when you are sending a Text message. You have selected text mode.



**Select characters by pressing digits repeatedly.**

*Example:*

**5**

**Press a digit**

1 time	result	J
2 times	result	K
3 times	result	L
4 times	result	5

**Note:** Key **1** is reserved for national characters.

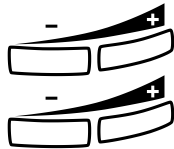

**Press the Volume Up key to enter the character.**

Moves cursor to next position. Use also for space.

**Press the Volume Down key as backspace to erase incorrect entry.**

*Example:*



**Enter the first character code, followed by the Volume Up key.**



**This sequence - numbers always followed by the Volume Up key - gives the word IN\_.**

**Note:** You can also write the following characters:  
? -, !: /# \*

**\***

**Press repeatedly.**

Write Text

## Accessories

This chapter describes optional features that can be used together with your BusinessPhone telephone.

---

### Expansion key panel

#### **Dialog 4224 Operator**

Each key panel offers 17 additional keys for storing of your most frequently used telephone numbers and functions, and for supervising extensions. Your telephone can be expanded with up to four key panels.

**Note:** *For the Dialog 4224 Operator, you need the optional key panel DBY 419 01.*

#### **Dialog 3214 Operator's Console**

Each key panel offers 17 additional keys for storing of your most frequently used telephone numbers and functions, and for supervising extensions. Your telephone can be expanded with up to four key panels.

**Note:** *If one or two key panels are used, the optional key panel DBY 409 01 may be used. However, if three or four key panels are used, all optional key panels must be of type DBY 409 02.*

---

## Option unit

### Dialog 4224 Operator

The Option unit DBY 420 01/1 is an optional accessory, to be installed on the bottom of your telephone set. The following devices can be installed via the Option unit:

- Extra bell or busy indication outside your door



To check or set the option unit for extra bell or for busy signal:

**Press and hold simultaneously until a ring signal is heard.**  
The display shows:

The Clear right key lamp indicates the setting of the option unit:

- Off=Extra bell
- On=Busy signal lamp
- Flashing=Combined extra bell & busy lamp.



**Press to change to busy signal,**

**Or:**



**Press to change to extra bell & busy signal,**

**Or:**



**Press to change to extra bell.**

**#**

**Press to save the setting and exit.**

*Note: If you do not press #, the phone automatically returns to idle about 30 seconds after the last key press.*

### Dialog 3214 Operator's Console

The Option unit DBY 410 02 is an optional accessory, to be installed on the bottom of your telephone set. The following devices can be installed via the Option unit:

- Tape recorder
- Extra bell or busy indication outside your door
- Enhanced Headset functionality

- PC Sound Card
- Second handset

**Note:** For people with impaired hearing the Option unit offers the possibility to amplify the receiving volume in the handset and headset.

## Extra handset

Useful for involving a second person in your conversation, for talking or just listening.

---

## Tape recorder

When a recording of the telephone conversation is needed, for evidence purposes, a tape recorder can be connected.

---

## Headset - Dialog 4224 Operator

The following headset functions are available.



### Activate/Deactivate the headset

**Press the Headset key to activate/deactivate.**



### Answer calls

**Press to have speech connection with the caller.**



**Clear**  **Press to terminate a Headset call.**

**Make calls**



**Dial the number.**

**Clear**  **Press to terminate the call.**

**Headset to handset**



**Lift the handset.**

**Handset to headset**



**Press the Headset key.**

**Headset with Group Listening**



**Press to toggle between headset with or without Group Listening.**

**Headset to handsfree**



**Press.**



**Press the Headset key.**

**Handsfree to headset**



**Press the Headset key.**

## Headset - Dialog 3214

The following Headset functions are available.

**Note:** To use the Headset functions with the Dialog 3214 your telephone has to be equipped with option unit DBY 410 02. How to install the option unit, see separate installation instructions provided with the option unit.

### Activate/Deactivate the headset



**Press the Headset key to activate/deactivate.**

**Note:** For the Dialog 3214, this key must be pre-programmed to handle calls via the headset.



### Answer calls

**Press to have speech connection with the caller.**



**Press to terminate a Headset call.**



### Make calls

**Dial the number.**



**Press to terminate the call.**



### Headset to handset

**Lift the handset.**



### Handset to headset

**Press the Headset key.**



**Headset with Group Listening**

**Press to toggle between headset with or without Group Listening.**



**Headset to handsfree**

**Press.**



**Press the Headset key.**



**Handsfree to headset**

**Press the Headset key.**

## Useful Hints

### Connections between external lines

With your BusinessPhone PBX, you can establish an external call diversion or a Conference with more than one external party or transfer an external call to another external destination (e.g. a mobile phone). These features are very useful for everyday business life.

**Note:** *When these features are used, your BusinessPhone will occupy at least two external lines.*

However, there may be disadvantages in connecting to several external lines. We would therefore like to draw your attention to the following:

- **Please do not transfer external calls to an external mailbox, to information systems or to external parties before they have answered.**
- **Cancel your calls by pressing the Clear key.**

If the external parties are not persons (mailbox, automated information or attendant systems, etc.), connections on external lines can last a long time, which can be costly. Moreover, such calls may occupy two of your system's external lines. You can restrict connections between the external lines by re-programming your system.

Please ask your system administrator or contact our service center for more information.

## Installation

### Dialog 4224 Operator

#### Install cables

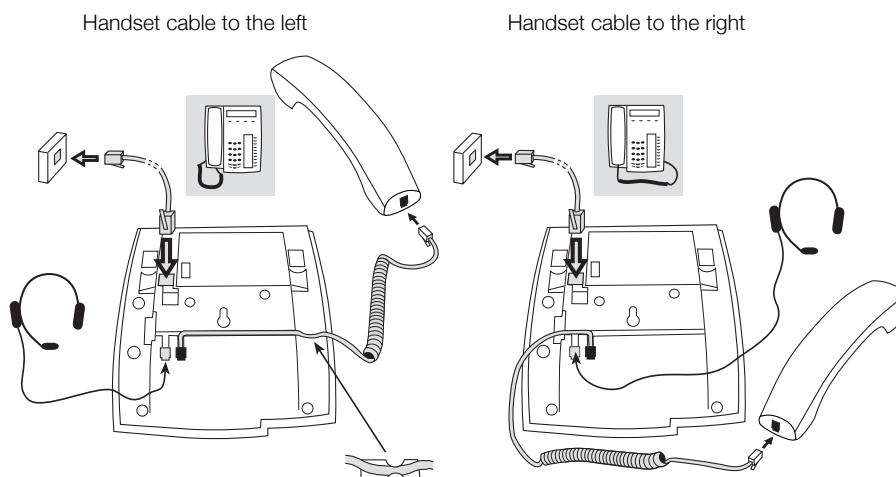

You can put the cable to the handset in the notch underneath the telephone. The cable to the exchange has to be plugged in LINE and the handset cable has to be plugged in HANDSET.

#### Change cables

To remove a cable, use a screwdriver to unlock the stop.

## Install stands and adapt telephone

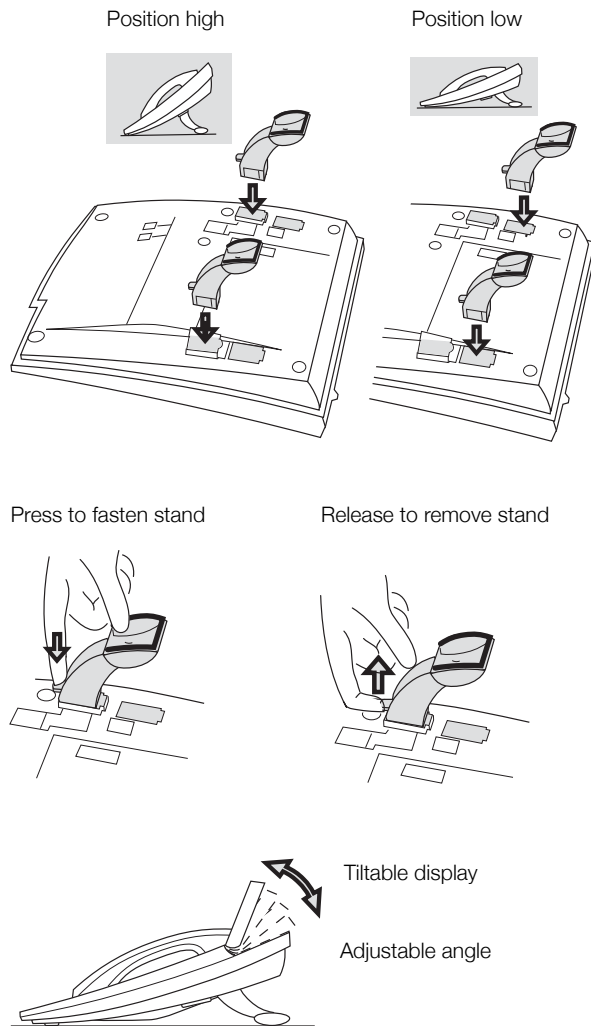

## Install key panels

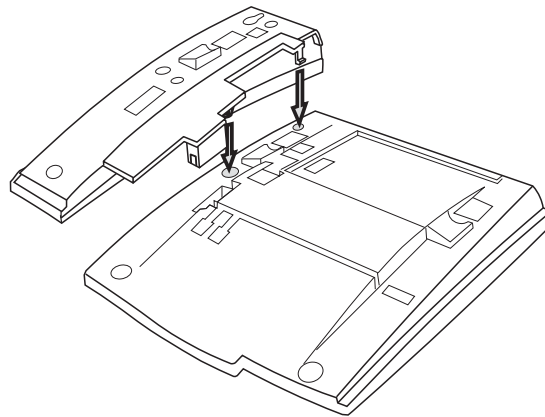

- 1 Remove the small plastic plate, marked DSS, i.e. with a screwdriver and connect the cable.**
- 2 Attach key panel unit.**
- 3 Secure with screws and install stand.**

**Note:** All key panels must be of type DBY 419 01 (three or four key panels can only be used in newer versions of the exchange).

**Stand positioning (1-4 key panels)**

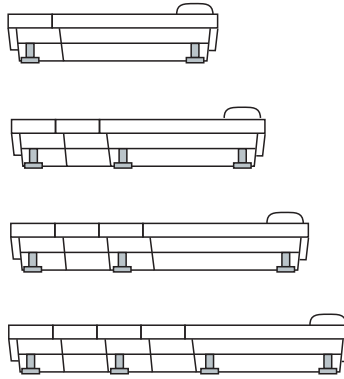

**Install card**

Use the Designation Card Manager to make and print your own key panel designation cards. The Designation Card Manager is included on the Enterprise Telephone Toolbox CD. For questions regarding the product, please contact your Aastra Certified Sales Partner.

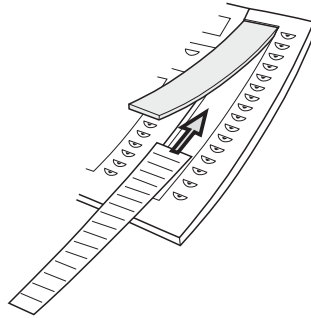



### Install pullout leaf

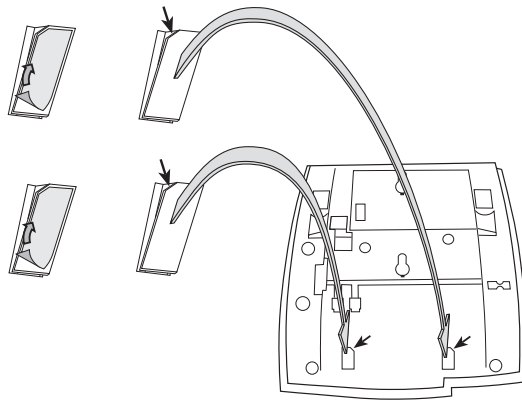

- 1 Remove the protective film from the guiding rails.**
- 2 Attach the guiding rails to the bottom of the phone, observing the direction of the “cut” corner.**

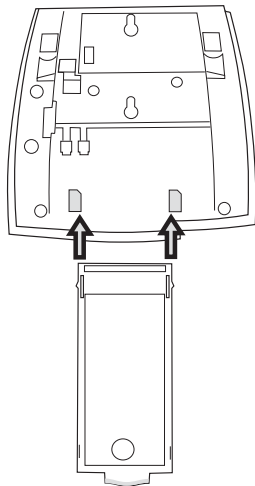

- 3 Insert the pullout leaf.**

## Wall mounting handset hook

The phone can be wall mounted without using a special console. Useful for instance in conference rooms or public areas.

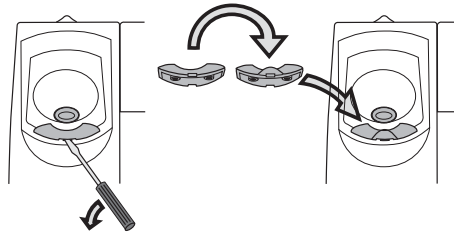

- 1 Use a screwdriver to remove the handset hook.**
- 2 Turn the hook upside down and insert.**

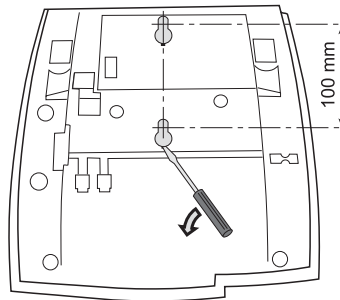

- 3 Use a screwdriver to remove the two plastic covers.**
- 4 Drill wall holes according to measure.**

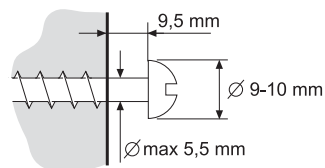

- 5 Mount screws according to measures and attach the phone.**

## Install card

Use the Designation Card Manager to make and print your own designation cards. The Designation Card Manager is included on the Enterprise Telephone Toolbox CD. For questions regarding the product, please contact your Aastra Certified Sales Partner.



---

## Placing the telephone

- Do not place your telephone on sensitive surfaces. Use a non-slippery pad to protect your furniture from possible damage.
- Do not place your telephone near sources of extreme heat, e.g. near the radiator.
- Make sure that the line cable isn't creased.

---

## Cleaning the telephone

Use a slightly moistened (not wet) soft cloth or an anti-static cloth and wipe off the telephone carefully. Do not use rough cloth, solvents or aggressive cleaning fluids. Any damages of the telephone, that are caused by non-observance of these instructions, are not part of the liability given by the manufacturer.

## Dialog 3214 Operator

### Install cables

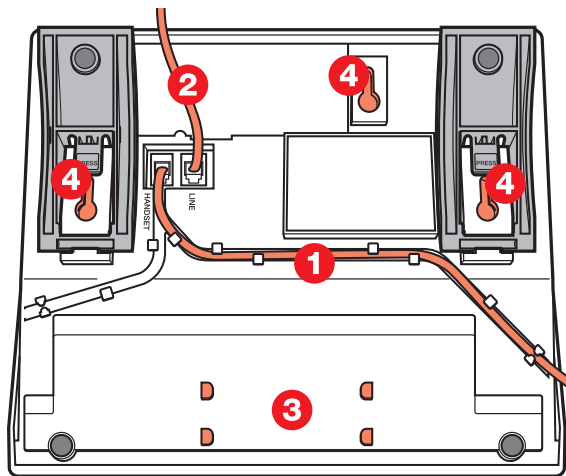

- 1 Cable to handset
- 2 Cable to exchange
- 3 Space for personal directory list (optional)
- 4 Wall mounting screw holes

You can put the cable to the handset in any of the two notches underneath the telephone. The cable to the exchange has to be plugged in LINE.

#### **Change cables**

To remove a cable, push down the plug stop. Use a screwdriver to unlock the stop.

## Wall mounting handset hook

When mounting on a wall, you have to pull out and turn the hook.

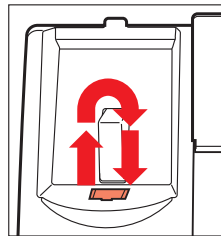

---

## Install stand and adjust telephone

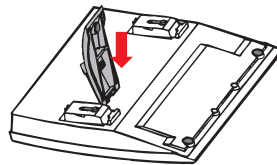

Press to decrease angle

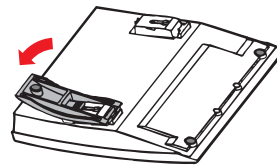

Pull to increase angle

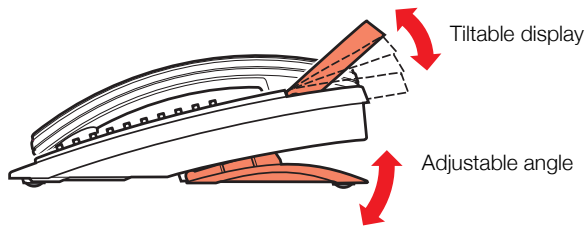
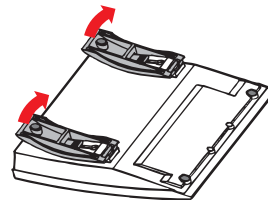
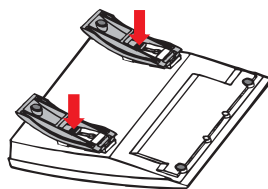

Tilttable display

Adjustable angle

## Install key panel

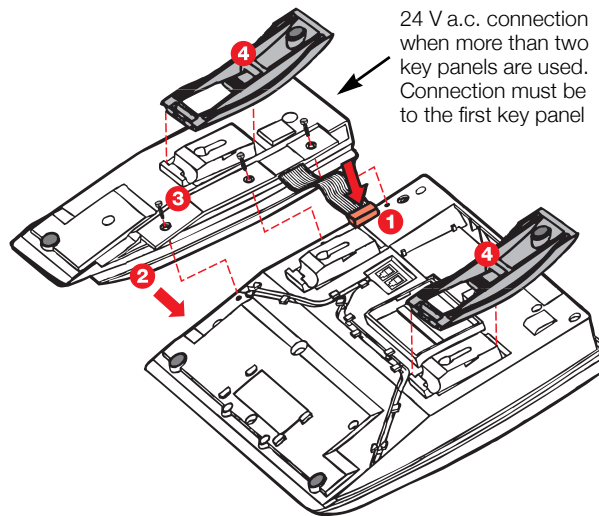

- 1 Connect cable
- 2 Attach key panel unit
- 3 Secure with screws
- 4 Install stand

When connecting one or two optional key panels to your telephone the DBY 409 01 key panel may be used. No external power cables are required for this key panel, as power is supplied from your telephone.

However, if three or four key panels are to be connected, the DBY 409 02 optional key panel must be used for all key panels connected to your telephone. Whereby, a 24 V a.c. power cable must be attached to the first key panel connected to your telephone to provide power to all key panels.

## Placing the telephone

- Do not place your telephone on sensitive surfaces. Use a non-slippery pad to protect your furniture from possible damage.
  - Do not place your telephone near sources of extreme heat, e.g. near the radiator.
  - Make sure that the line cable isn't creased.
- 

## Cleaning the telephone

Use a slightly moistened (not wet) soft cloth or an anti-static cloth and wipe off the telephone carefully. Do not use rough cloth, solvents or aggressive cleaning fluids. Any damages of the telephone, that are caused by non-observance of these instructions, are not part of the liability given by the manufacturer.

## Glossary

### **Abbreviated Number Dialling**

Initiating a call to a pre-programmed number by dialling a code or pressing a key. Short numbers can be:

1. *Common, which means that all extensions can use them.*
2. *Individual, which means that they are programmed and used by each extension separately (71 numbers).*

See section "[Abbreviated Numbers](#)" on page 32.

### **Account Number**

To place cost for external calls on a selected Account Number (up to 15 digits).

See section "[Other Useful Features](#)" on page 86.

### **Announcing**

The operator informs an extension of an incoming call before placing the call.

### **Automated Attendant**

A facility which sends voice instructions to internal and external callers, providing all options which can be chosen. Voice instructions lead the caller to the desired destination. See section "[Other Useful Features](#)" on page 86.

### **Callback**

An indication to a busy extension, to inform the person that you want to speak to him/her. See section "[Messages](#)" on page 62.

### **Camp-on**

To place (queue) a call to a busy extension. The extension may have one or more calls camped on already. Camped on calls are presented to the extension in the order in which they arrive. See section "[Outgoing Calls](#)" on page 23.

### **Congestion**

Lack of free voice channels prevents calls from being connected.

### **Counter**

The counter keeps track of the time and cost of your calls. See section "[Call Metering](#)" on page 45.

### **Dial-by-Name**

Initiation of a call by operating a single key. Internal numbers (or Common Abbreviated Numbers) can be stored on each extension. See section "[Abbreviated Numbers](#)" on page 32.

### **Directory number**

Numbers with 1-8 digits which are assigned to extensions or external lines or as Common Abbreviated Numbers.

### **Direct Inward System Access (DISA)**

If you are working externally, the DISA function enables you to make external calls (long distance) via the company PBX. You only pay for the call to your company. See section "[Other Useful Features](#)" on page 86.



**Diversion**

Incoming calls to an extension are diverted to another directory number (extension, Common Abbreviated Number or the operator).

There are three possibilities:

1. *Direct, which means that all calls to an extension are forwarded directly.*
2. *On no reply, which means that a call is forwarded if it is not answered within a certain time.*
3. *On busy, which means that a call is forwarded if the extension is busy.*

See section [“Call Forwarding”](#) on page 54.

**Diversion Bypass**

This is useful for letting urgent calls through to an extension where diversion is active. See section [“Call Forwarding”](#) on page 54.

**Extension**

All telephones connected to the PBX have a unique internal number. If your telephone is equipped with a display, you can see your number.

**Forced release**

Disconnecting a third (undesired) party during Intrusion. See section [“Outgoing Calls”](#) on page 23.

**Function code**

A digit code that corresponds to a specific function.

**Group call**

A group of extensions can have a common number beside their individual extension numbers. Any extension within the group can answer the call.

**Hold**

To put a call on hold. See section [“During Calls”](#) on page 35.

**Identification**

If an extension is busy, the operator can identify the other conversation party.

**Information**

Internal callers are informed about absence and time of return. External callers are diverted to the operator, where the same information is available. The operator can insert text or voice information for any extension in the system.

This is useful for keeping the stored information up-to-date for colleagues who are out of their offices. Information can be of three kinds:

1. *Pre-programmed text information.*
2. *Text information (only to display phones).*
3. *Voice information.*

**Intercom Line**

A two-way direct call function between two extensions, for instance an executive-secretary communication. See section [“Other Useful Features”](#) on page 86.

**Intrusion**

To intrude on an ongoing call when a requested extension is busy. See section [“Outgoing Calls”](#) on page 23.

**ISDN**

Integrated Services Digital Network. Provides your system with supplementary services from the public net. See section [“ISDN Facilities”](#) on page 81.

**Least Cost Routing**

A function that automatically selects the cheapest way to connect your external call (not necessarily the shortest distance).

See section [“Least Cost Routing”](#) on page 91.

**Loop keys**

The operator can use the three Loop keys to supervise call progress when placing calls with a free or a busy extension. A call that is being placed or is put on hold via a Loop key can be retaken at any time.

**Loudspeaker Paging**

All members of an extension group are paged, i.e. receive a short, sharp tone on the loudspeaker followed by a Voice message from the sender. See section [“Group Features”](#) on page 76.

**Mailbox**

The Mailbox system controls the messages that are left for or sent by you when you are absent. See section “[Messages](#)” on page 62.

**Message**

A message can be sent to any extension. This is useful when you receive the busy tone or get no answer. There are three kinds of message:

1. *Call Me message.*
2. *Text message (only to a display phone).*
3. *Voice message.*

See section “[Messages](#)” on page 62.

**Metering**

Outgoing external calls can be metered on individual call meters or specified Account Numbers. See section “[Call Metering](#)” on page 45.

**Monitoring**

Allows the operator to monitor a call while handling new calls. There is only one listening connection from the operator to the monitored call. The monitoring key can be used in the same way as a Loop key. See section “[During Calls](#)” on page 35.

**Music on hold**

If a music source is connected to the system, all external callers that are on hold will hear music.

**Mute**

To switch the microphone temporarily off. See section “[During Calls](#)” on page 35.

**Night Switching**

Used for directing all incoming calls to one extension (answering position), for example when the office is closed. See section “[Attendance](#)” on page 19.

**Notification**

Allows the operator to notify a busy extension of a new call. The operator will be recalled when the extension becomes free. See section “[Outgoing Calls](#)” on page 23.

**Off duty**

A key on the operator console. When Off duty is activated all external calls to the operator queue will be routed to an alternative answering position. The operator can still use the console as a normal phone when off duty and can be called by its individual extension number. If a call is left unanswered for 30 seconds (this time can be changed) the console is marked unattended automatically. The lamp lights and flashes briefly.

**Password**

A four-digit code needed to e.g. block your extension and retrieve messages from the Mailbox system. You can set your own Password. See section “[Security](#)” on page 73.

**PBX**

Private Branch Exchange. Your telephone switching system (e.g. BusinessPhone 250).

**Place a call**

Connecting a call to the requested extension.

**Pre-defined text**

Pre-programmed Absence Information. See section “[Messages](#)” on page 62.

**Put on hold**

A call that cannot be placed for the moment, e.g. requested extension is busy, can be put on hold and, after recall, be placed later.

**Queue**

Calls to the operator are queued. New calls are placed in a common queue for all operators. Recalls are placed in the operator’s individual call queue.

**Recall**

The operator is recalled after 30 seconds (this time can be changed) when a call has been camped on or placed with a non-replying extension.

**Serial call**

An external caller may wish to speak to several extensions sequentially. The serial call will recall the operator each time an extension terminates a conversation. See section [“During Calls”](#) on page 35.

**Third party**

A third connection (person), which can be included in an ongoing two person conversation. The connection can be internal or external. See section [“During Calls”](#) on page 35.

**Tie line**

An external line from the private network.

**Transfer**

During an internal or external ongoing call you can make an inquiry and then transfer the call to another party (internal or external). See sections [“During Calls”](#) on page 35 and [“Useful Hints”](#) on page 100.

**Trunk line**

A trunk line is the same as an external line. Can be either digital or analog

## Index

### A

- Abbreviated Numbers 32
- Absence Information 57
  - Change information 60
  - Enter information 57
  - Receive information for diverted calls 61
- Accessories 94
  - Expansion key panel 94
  - Extra handset 96
  - Headset 98
  - Option unit 95
  - Tape recorder 96
- Account Number 90
- Answer an incoming call from an ISDN-line 82
- Answer calls 22
- Attendance 19
  - Night Switch 20
  - Off Duty 19
- Automated Attendant 90
- Automatic Redial 25

### B

- Background Music 87
- Block extension 75
- Busy extension 27
- Busy external line 31
- Bypass blocked extension 74

### C

- Call Forwarding 54
  - Change diversion address for another extension 54
- Call Metering 45
  - Cost of the last call 45
  - Integrated System Check 51
  - Operator supervised call 52
  - Printout 49
  - Read out cost counter for others 46
  - Read out your own cost counter 45

- Call Ordering 42
  - Call ordering off line 43
  - Call ordering on line 43
  - Dial tone ordering 42
- Call ordering off line 43
- Call ordering on line 43
- Change diversion address for another extension 54
- Change information 60
- Change Password 73
- Change sending extension 68
- Check and store received messages 64
- Check sent messages 69
- Common Abbreviated Numbers 33
- Common Bell 78
- Common Mailbox system 63
- Cost of the last call 45

### D

- Description 6
  - Dialog 3214 Operator 9
  - Dialog 4224 Operator 6
  - Display info 14
  - Lamp indications 13
  - Signals 18
  - Tones 17
- Dial tone ordering 42
- Dial-by-Name 33
- Dialog 3214 Operator 9
- Dialog 4224 Operator 6
- Dictaphone function 72
- Direct Inward System Access (DISA) 89
- Display info 14
- Diverted extension 28
- Doorphone 88
- During Calls 35
  - Conference 38
  - From handset to handsfree 35
  - From handsfree to handset 35

- Group Listening 35
  - Individual Hold 39
  - Individual Hold and monitor 39
  - Mute 36
  - Operator hold 40
  - Serial calls 41
  - Transfer 36
- E**
- Enter information 57
  - Expansion key panel 94
  - Extra handset 96
- F**
- Forward a Voice message 70
  - From handset to handsfree 35
  - From handsfree to handset 35
- G**
- Group Features 76
    - Common Bell 78
    - Group Hunting 79
    - Key system 76
    - Loudspeaker Paging 78
    - Supervision 77
    - Telephone Attendance 77
  - Group Hunting 79
  - Group Listening 35
- H**
- Headset 98
- I**
- Incoming Calls 21
    - Answer calls 22
    - Silent ringing 22
  - Individual Abbreviated Numbers 33
  - Individual Hold 39
  - Individual Hold and monitor 39
  - Installation Dialog 3214 108
    - Adjust 109
    - Cables 108
    - Cleaning 111
    - Key panel 110
    - Placing 111
    - Stand 109
    - Wall mounting handset hook 109
  - Installation Dialog 4224 101
    - Adapt 102
    - Cables 101
- Card 107
  - Cleaning 107
  - Key panels 103
  - Placing 107
  - Pullout leaf 105
  - Stands 102
  - Wall mounting handset hook 106
- Integrated System Check 51
  - Intercom Line 88
  - Intrusion and forced release 29
  - ISDN Facilities 81
    - Answer an incoming call from an ISDN-line 82
    - Make an external call on an ISDN-line 83
    - Malicious Call Identification 84
    - Number Identification 81
    - Number Secrecy 85
- K**
- Key system 76
- L**
- Lamp indications 13
  - Last External Number Redial 24
  - LCR 91
  - Least Cost Routing 91
  - Loudspeaker Paging 78
- M**
- Make an external call on an ISDN-line 83
  - Make external calls 24
  - Make internal calls 23
  - Malicious Call Identification 84
  - Messages 62
    - Change sending extension 68
    - Check and store received messages 64
    - Check sent messages 69
    - Common Mailbox system 63
    - Dictaphone function 72
    - Forward a Voice message 70
    - Password protection 62
    - Repeat message 68
    - Returned messages 71
    - Send Message 66
  - Mute 36
- N**
- Number Identification 81
  - Number Secrecy 85

**O**

- Off Duty 19
- Operator hold 40
- Operator supervised call 52
- Option unit 95
- Other Useful Features 86
  - Account Number 90
  - Automated Attendant 90
  - Background Music 87
  - Direct Inward System Access (DISA) 89
  - Doorphone 88
  - Intercom Line 88
  - Least Cost Routing 91
  - Reminder 86
- Outgoing Calls 23
  - Abbreviated Numbers 32
  - Automatic Redial 25
  - Busy extension 27
  - Busy external line 31
  - Common Abbreviated Numbers 33
  - Dial-by-Name 33
  - Diverted extension 28
  - Individual Abbreviated Numbers 33
  - Intrusion and forced release 29
  - Last External Number Redial 24
  - Make external calls 24
  - Make internal calls 23
  - Save external number 25
  - Supervise long distance calls 32

**P**

- Phone Book 34
- Printout 49

**R**

- Read out cost counter for others 46
- Read out your own cost counter 45
- Receive information for diverted calls 61
- Reminder 86
- Repeat message 68
- Returned messages 71

**S**

- Save external number 25
- Security 73
  - Block extension 75
  - Bypass blocked extension 74
  - Change Password 73
- Send Message 66
- Serial calls 41
- Signals 18
- Silent ringing 22
- Supervise long distance calls 32
- Supervision 77

**T**

- Tape recorder 96
- Telephone Attendance 77
- Tones 17
- Transfer 36

**U**

- Useful Hints 100

**W**

- Welcome 4
- Write Text 92



Subject to alteration without prior notice.  
For questions regarding the product,  
please contact your Aastra Certified Sales Partner.  
Also visit us on [www.aastra.com](http://www.aastra.com)

© Aastra Telecom Sweden AB 2008.  
All rights reserved.  
EN/LZTBS 170 340 R2A